

# EvolutionRO™

High-Flow Reverse Osmosis System

USER MANUAL



**HydroLogic®**  
PURIFICATION SYSTEMS



WISHING WELL

*...purely protecting Life*

## DESCRIPTION

The **EvolutionRO** is a customized Reverse Osmosis water filter that is made in the USA. This system is capable of reducing up to 95% of most contaminants. This system is designed and built for use with hydroponic or horticultural applications. This system is built to give the maximum amount of flow from the membrane while sending less wastewater to the drain, compared to similar RO filters. Please read the following setup and maintenance guide to get the maximum results from your filter.

## TABLE OF CONTENTS

Description, Table of Contents.....	p 1
Precautions.....	p 2
Filter Replacement Schedule .....	p 3
Includes .....	p 4
Installation.....	p 5-6
Performance and Dimensions.....	p 7
Component Specs .....	p 8
Quick Connect Fittings.....	p 9
Warranty and Support.....	p 10
Troubleshooting .....	p 11
Options .....	p 12
Filter Replacement Log .....	p 13
User Notes .....	p 14

## PRECAUTIONS

- ◆ Do not use this product to make safe drinking water from non-potable water sources. Do not use the system on microbiologically unsafe water, or water of unknown quality without adequate disinfection before or after the system.
- ◆ Temperature of the water supply to the **EvolutionRO** must be between 40°F–100°F (4°C–38°C). **Do not install on hot water lines.**
- ◆ High levels of certain contaminants in the incoming water may prematurely foul the membranes and/or the pre-filter. Softened water is recommended for optimal system performance and RO membrane life.
- ◆ The black drain line must be unrestricted at all times.
- ◆ Keep out of direct sunlight or high intensity lights, which degrade the housing and fittings over time. Protect unit against freezing to prevent cracking of the filter housing and water leakage. **Replace housings every three years.**
- ◆ When replacing filter cartridges use the filter wrench to remove housing. Do not use the wrench to tighten the housings. Hand tighten the housings only. Take care not to over-tighten.
- ◆ Do not install where leakage or failure may cause damage to property.
- ◆ If you are going to store or not use your **EvolutionRO** for an extended period of time (2 weeks+), it is recommended that you remove your membranes, seal them in plastic and put in refrigerator. Once removed, membranes are no longer under warranty.
- ◆ Keep the lengths of tubing short. Longer lengths of tubing will decrease inlet pressure and ultimately system performance.
- ◆ Do not use grease containing petroleum products.
- ◆ When the system is initially turned on, water may temporarily sputter until all the air is purged. Allow up to 24 hours for any trapped air noise in the system to subside.
- ◆ The flow rate of product water can drastically decrease due to low psi and low temperature, especially in the winter. In some cases with cold temperature and/or low pressure predicted flow rate can drop by as much as 50% or more. A combination of cold water and low pressure can drop flow rates even further. This is the case with all RO technology and is not unique to the **EvolutionRO**. The ratio of wastewater to product water can also get drastically worse due to low pressure and low temperature. You can overcome some of these issue by increasing pressure with our optional booster pump (**HL 29014** See pg. 12) or by increasing inlet temperature.

We do not recommend hooking any RO system up to your hot water tank lines because hot water tanks contain lots of minerals and the water can be too hot. *A safe way to increase temperature is with an on demand or flash style water heater set at below 100°F (37.7°C). For people with adequate pressure but decreased water temperature a flash water heater is a great way to increase flow rates.*

# FILTER REPLACEMENT SCHEDULE

**ChloroShield (HL 22019)**: The carbon filter reduces sediment and certain chemicals, such as chlorine and chloramines from the water. Depending on water use and the amount of impurities, this filter should be replaced a minimum of 2,500 gallons of purified water produced.

**EvolutionRO membrane (HL 22045)**: The functional life of the EvolutionRO membranes will vary based on feed water quality. Product water should be tested periodically to verify the membranes are performing properly. For most applications, the EvolutionRO membranes should be replaced every 6 months to two years.

**BE SURE TO CHANGE YOUR FILTERS BASED ON THE FILTER REPLACEMENT SCHEDULE!**

Filter	HydroLogic Part #	Replacement Schedule
<b>ChloroShield</b>	<b>HL 22019</b>	2,500 gallons of purified water
EvolutionRO Dry Membrane 600 GPD	<b>HL 22045</b>	6 months–2 years

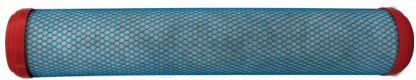

**HL 22019**



**HL 22045**

# EvolutionRO INCLUDES



1. Manifold (X1)
2. Filter Housing (X3)
3. **ChloroShield** Carbon Filter (X1)
4. 600+ Gallon/Day **EvolutionRO** Membrane (X2)
5. **White** Feed Fitting (X1)
6. **Blue** Product Water Fitting (X1)
7. **Orange 1:1** Ratio Drain Fitting (X1)
8. **Green 2:1** Ratio Drain Fitting (X1)
9. Lock Bar (X1)
10. Pressure Gauge w/Tee Fitting (X1)
11. Support Leg/Housing Wrench (X1)
12. White Tubing (6')
13. Black Tubing (10')
14. Blue Tubing (10')
15. Garden Hose Connector (X1)
16. In-line Shut-Off Valve (X1)



1.



2.

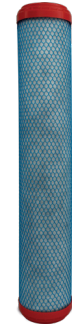

3.



4.



5.



6.



7.



8.



9.



10.



11.



12.



13.



14.



15.



16.

# EvolutionRO INCLUDES

## IMPORTANT: BEFORE YOU START

To ensure optimal efficiency, the carbon filter **MUST BE FLUSHED FOR 10 MINUTES, PRIOR TO MEMBRANE INSTALLATION**. To do this, follow the steps below but **DO NOT** install the membranes, only the carbon filter. After the steps are complete, run the system for 10 minutes. Once the flush is complete, the system is ready to return to STEP 9 for membrane installation. Flushing the carbon filter is extremely important and must be done on startup or anytime the carbon filter is replaced.

### STEP 1:

Install **ChloraShield** carbon filter. The filter can only be installed in the manifold in the position shown. Note that the O-ring is making the seal. The other two openings in the manifold are for the membranes. If starting for the first time **DO NOT** install membranes; complete installation without them and run for 10 minutes to flush the carbon. If you are replacing the carbon filter, **YOU MUST REMOVE MEMBRANES FIRST**.

Afterwards, go back to STEP 9 to install the two membranes.



### STEP 2:

Put a thin layer of included lube on the O-rings of the three housings. Be sure to completely cover the O-rings but save some for STEP 9. Housing can then be installed, screwed in clockwise, hand-tight (even if empty, required for carbon flush).

**There's no need for the flange on the bottom of the housing to come in contact with the flange on the manifold.**



Apply lube here on all three housings.

### STEP 3:

Lube the O-rings on each of the 3 elbow connector fittings and push them into the corresponding ports on the manifold as shown.



**The back of each elbow connector fitting has a symbol that corresponds to the symbol next to the manifold ports.**

### STEP 4:

Install the manifold lock bar clip by matching symbols on the clip to symbols on the manifold (**square to square, arrow to arrow**).



# EvolutionRO INCLUDES

## STEP 5:

Install the pressure gauge assembly. Push the short length of tubing into the left side of the gauge. Push the other end of the tubing into the elbow connector fitting as shown.



## STEP 6:

Install the Support Leg/Housing Wrench, as shown.



## STEP 7:

Install the white inlet tubing by pushing the tubing into pressure gauge fitting. Push the garden hose inlet fitting onto other end of tubing. This fitting is compatible with garden hoses and hose bibs.



## STEP 8:

Install blue purified water tubing and black wastewater tubing into corresponding elbow connector fittings as shown. The in-line shut-off valve should only be installed on the blue purified water line to shut system off/on.



**Flush for TEN MINUTES. Once properly flushed, remove tubing and use wrench to remove the two EMPTY membrane housings.**

## STEP 9:

Apply a thin layer of lube to both o-rings on the two membranes. Carefully push the first membrane into the position shown in STEP 10. Push it straight down into the hole of the manifold until both o-rings are seated in the hole. Install housing over membrane. **Do not rock membrane back and forth to install. Repeat this step for second membrane.**



## STEP 10:

Once the two membranes are properly seated, re-install housings and tubing. Run system for two minutes to check for leaks. If leaking, use the wrench to tighten the housings, one clockwise quarter-turn.



**Reminder: Anytime you change the carbon filter, it must be flushed without membranes for at least 10 minutes.**

# PERFORMANCE

## TFC Membrane Rejection Chart

The TFC membrane rejection chart can be very helpful as a general guideline, but is not a guarantee. Every water source has a different chemistry, temperature and TDS, and it is best to test your water thoroughly to determine your unique water profile.

A good place to start is EWG.org, just type in your zip code to determine what contaminants (if any) you may be dealing with.

Ion	Symbol	% Rejection
Aluminum	Al <sup>+3</sup>	97-98
Ammonium	NH <sub>4</sub> <sup>+</sup>	85-95
Arsenic	As	90-95
Borate	B <sub>4</sub> O <sub>7</sub> <sup>2-</sup>	30-50
Boron	B	60-70
Bromide	Br <sup>-</sup>	93-96
Cadmium	Cd <sup>2+</sup>	93-97
Calcium	Ca <sup>+2</sup>	95-98
Chloride	Cl <sup>-</sup>	92-98
Chromate	CrO <sub>4</sub> <sup>2-</sup>	85-95
Copper	Cu <sup>2+</sup>	96-98
Fluoride	F <sup>-</sup>	93-95
Iron	Fe <sup>2+</sup>	96-98
Lead	Pb <sup>+2</sup>	95-98
Magnesium	Mg <sup>+2</sup>	95-98
Manganese	Mn <sup>+2</sup>	97-98
Mercury	Hg <sup>2+</sup>	95-97
Nickel	Ni <sup>2+</sup>	97-98
Nitrate	NO <sub>3</sub> <sup>-</sup>	90-95
Phosphate	PO <sub>4</sub> <sup>3-</sup>	95-98
Polyphosphate	PolyP	96-98
Potassium	K <sup>+</sup>	92-96
Silica	Si	85-90
Silicate	SiO <sub>2</sub> <sup>2-</sup>	92-95
Silver	Ag <sup>+</sup>	95-97
Sodium	Na <sup>+</sup>	92-98
Sulfate	SO <sub>4</sub> <sup>2-</sup>	96-98
Thiosulfate	S <sub>2</sub> O <sub>3</sub> <sup>2-</sup>	97-98
Zinc	Zn <sup>+2</sup>	97-99

## DIMENSIONS

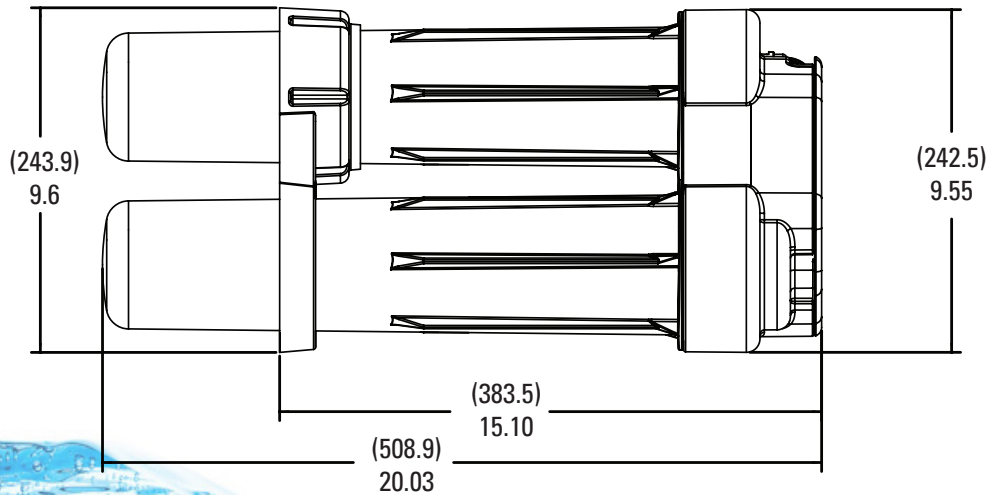



# COMPONENT SPECIFICATIONS

## ChloroShield HL 22019:

This combination of high performance carbon, unique binders, and proprietary manufacturing processes delivers exceptionally low pressure drop, high dirt holding capacity, and excellent contaminant reduction.

- ◆ Operating pressure 20–125 psi (1.38–8.62 bar)
- ◆ Operating temperature 40°F–125°F (4°C–52°C)
- ◆ 1 micron nominal filtration
- ◆ Exceptionally low pressure drop
- ◆ Proposition 65 compliant
- ◆ Meets NSF61 standards
- ◆ Industry leading performance
- ◆ Wishing Well member
- ◆ 2,500 gallons of RO water capacity

## RO Membrane: HL 22045

EvolutionRO HydroLogic Membranes are recognized as one of the industry's most reliable and highest performing membranes that deliver consistent performance and quality. Advanced membrane technology and manufacturing processes allow these membranes to deliver consistent results.

- ◆ Dry rolled element—extended life
- ◆ 95%+ PPM Rejection
- ◆ DOW flat sheet material
- ◆ Improved system performance
- ◆ Superior quality and cost savings
- ◆ Individually tested and sanitized

## Minimum and Maximum Operating Conditions

Condition	Minimum	Maximum
◆ Inlet Pressure	40 psi (2.76 bar)	80 psi (5.52 bar)
◆ Inlet Temperature	40°F (4.44°C)	100°F (37.78°C)
◆ Inlet TDS	50 mg/L	2,000 mg/L
◆ Inlet Hardness	0 mg/L (0 grain)	171 mg/L (10 grain)
◆ Inlet Chlorine	0 mg/L	1.0 mg/L
◆ Inlet Iron	0 mg/L	0.1 mg/L
◆ Inlet Manganese	0 mg/L	10 0.05 mg/L
◆ Inlet pH	4	10
◆ Inlet Turbidity	0	1 NTU



# QUICK CONNECT FITTINGS (QC)

## Connecting QC Fittings:

Push tubing firmly into the fitting, all the way until the tube stops. The collet (gripper) has stainless steel teeth which hold the tube firmly in position while the O-ring provides a leak proof seal. Pull tubing to check for security. If some tube pulls out, then push it all the way in again until it stops. It is good practice to test the system prior to leaving site and/or before use.

## Disconnecting QC Fittings:

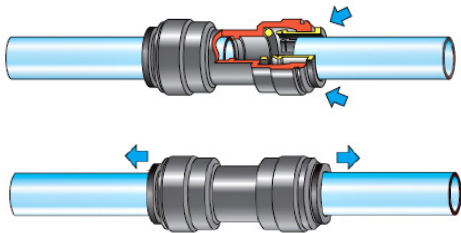

**Link To Instruction Video**

<https://bit.ly/2RJOqLq>



Ensure system is depressurized before removing fittings then push in the collet evenly against the face of the fitting. With the collet held in this position the tube can be removed by simply pulling. You can use a collet release tool (**HL 24010**, available from your dealer). The fitting can then be re-used. If the tubing has been removed several times you may see score marks on the ends, and this can lead to leaks. It is best to cut the end off of the tubing with a sharp blade, being careful to cut straight across. Any angle to the cut can cause a leak.

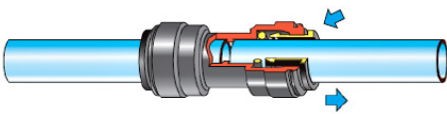

Please visit [hydrologicsystems.com](http://hydrologicsystems.com) for tutorial videos on the **EvolutionRO**.

## WARRANTY AND SUPPORT

**Do not bring unit back to the dealer, contact HydroLogic directly for questions and warranty issues. We can quickly assist you by phone.**

**A one-year warranty against manufacturer's defects comes with each unit.** *These defects must be reported to HydroLogic upon receiving the merchandise, when the box is opened, or immediately thereafter. For other issues that may arise throughout the lifetime of the product, please contact HydroLogic directly for technical support.*

**This does not include clogged or damaged pre-filters or RO membranes due to lack of regular maintenance or excessive sediment, chlorine, chloramines, iron, silica, manganese, sulfur, or PPM in the source water.** This warranty also excludes damage caused by using the unit outside of the specified operating parameters listed on page 8. Do not operate unit if incoming pressure exceeds 80 psi or there is problem with water hammer or pressure spikes.

The manufacturer believes the information and data contained herein to be accurate and useful. The information and data are offered in good faith, but without guarantee, as conditions and methods of use of products are beyond the manufacturer's control. The manufacturer assumes no liability for results obtained or damages incurred through the application of the presented information and data. It is the user's responsibility to determine the suitability of the products for the user's specific end uses.

**Tech Support Contact:**  
**techsupport@hydrologicsystems.com**  
**1-888-426-5644**

**Visit us on the web at: [www.hydrologicsystems.com](http://www.hydrologicsystems.com). There are a variety of videos under the resources tab.**

**WARNING: USING NON-HYDROLOGIC REPLACEMENT FILTERS OR MEMBRANES WILL VOID THE WARRANTY**



# TROUBLESHOOTING

## **Q: Why is the system leaking?**

**A:** This can be due to various reasons, including lack of Teflon tape at threaded fittings, tubing not being pushed in all the way to the quick connect fittings, or improperly seated O-rings in pre-filter and membrane housings. It is also important to make sure the ends of the tubing have a clean cut before inserting them into the quick connect fittings (see pg. 9) Please call us if you're experiencing any leaks.

## **Q: Why did the filter housing crack?**

**A:** This can be due to freezing conditions, excessive pressure spikes, or long-term exposure to high intensity lighting. Replacement housings are available and should be replaced every three years.

## **Q: Why is the pH of the purified water higher/lower than the source water?**

**A:** The pH of the purified water depends entirely on source water chemistry. Customers can experience either slightly lower or higher pH after filtration. This is completely normal for Reverse Osmosis technology. Since RO water is almost pure H<sub>2</sub>O and has no ability to buffer pH, the actual pH reading will not be accurate until you add minerals back.

## **Q: Why are both the 1:1 and 2:1 Flow Restrictors included in the box?**

**A:** The Flow Restrictor(s) determines your waste to purified water ratio. HydroLogic has always provided two options for the waste to purified water ratio, because water conditions vary across the world; one fixed ratio would not work for every water condition.

## **Q: My product flow rate is low. What could be happening?**

**A:** It could be a few different things. First, check for leaks or line kinks. If feed pressure is still low, you may need to install a pump. Water temperature may also be too low. Be sure and check the filter, it may be time to replace your membranes.

## **Q: Why does concentrate water continue to run to drain after shut-off?**

**A:** This could be caused by a clogged filter or by a leak. It is also possible that the system is too far away from the the float valve or ball valve, preventing sufficient back pressure. Try using a shorter black waste line to see if that solves the problem.



# OPTIONS



## TDS Monitor HL 28010

Measures PPM of dirty water going in and pure water going out. Monitors performance of your membranes.



## Pressure Regulator HL 26020

Required for water pressure over 80 psi. Fully adjustable from 0–125 psi.



## PreEvolution™ HL 31027

Recommended when using more than 300 gallons per week on average. The PreEvolution adds 2 extra stages of pre-filtration. Extends filter life to 7,500 gallon.



## Pressure Booster Pump for Continuous Duty HL 29014

For higher flow rates or low inlet pressure. Heavy duty booster pump for continuous use.



## Wall Mount Bracket HL 10057

Stainless steel, heavy duty bracket to mount your system on the wall.



## Drain Saddle HL 10055

The optional drain saddle is an alternative way to run your drain line.



## Flowmaster HL 19020

Gallon meter and filter capacity monitor. Indicates when to change your filters.



## UV Sterilizer Kit HL 35010

Kills up to 100% of all bacteria and viruses. Ensures the safest water possible.



## Float Valve HL 27020

Fill any tank or reservoir unattended. Can be installed in lid or sidewall of tank. Never flood your garden again!



## Leak Detector HL 28002

Turns off inlet water to system if leak is detected to prevent damage.



## De-Ionization Add-On Kit HL 33006

Delivers 0 PPM water. Removes final traces of Total Dissolved Solids.







# EvolutionRO™

*High-Flow Reverse Osmosis System*

370 Encinal Street  
Suite 150  
Santa Cruz, CA  
95060

ph: 888.426.5644  
fax: 831.336.9840

techsupport@hydrologicsystems.com  
hydrologicsystems.com



ACCREDITED  
BUSINESS

