

HYDROID SYSTEM USER MANUAL



888-426-5644

INFO@HYDROLOGICSYSTEMS.COM

TECHSUPPORT@HYDROLOGICSYSTEMS.COM

TABLE OF CONTENTS

TABLE OF CONTENTS.....	2
QUICK CONNECT FITTINGS.....	3
CONNECTING QUICK CONNECT FITTINGS.....	3
DISCONNECTING QUICK CONNECT FITTINGS.....	3
INTRODUCTION.....	4
SAFETY.....	5
PRECAUTIONARY STATEMENTS.....	5
HYDROID SCHEMATICS.....	6
COMPONENTS AND FILTRATION DESCRIPTION.....	8
CONTROLLER.....	8
PRE-FILTRATION.....	8
FEED PRESSURE GAUGE.....	8
LOW PRESSURE SWITCH.....	8
PUMP.....	9
PUMP PRESSURE GAUGE.....	9
MEMBRANES.....	9
CONCENTRATE PRESSURE GAUGE (DRAIN).....	9
CONCENTRATE FLOW METER (DRAIN).....	9
PRODUCT FLOW METER (PURIFIED WATER).....	9
BLEND VALVE.....	9
FEED WATER AND OPERATION SPECIFICATIONS.....	10
OPERATING LIMITS*.....	10
DESIGN BASIS AND DESIGN NOTES.....	11
SYSTEM INSTALLATION OVERVIEW.....	12
CHOOSING A LOCATION.....	12
INLET ½" QC FITTING (FEED).....	12
PRODUCT ½" QC FITTING (PURIFIED WATER).....	12
CONCENTRATE ½" QC FITTING (DRAIN).....	13
ELECTRICAL.....	13
TANK.....	13
SYSTEM PURGING / INITIAL START-UP.....	15
OPERATING DO'S AND DON'TS.....	16
FILTER REMOVAL AND INSTALLATION.....	17
MEMBRANE ELEMENTS.....	19
REJECTION, RECOVERY AND FLOW RATES.....	20
MEMBRANE PERFORMANCE.....	20
REJECTION.....	20
RECOVERY.....	20
TEMPERATURE CORRECTION FACTORS FOR MEMBRANES.....	21
OPERATING LOG.....	22
PREPARING UNIT FOR STORAGE.....	23
TROUBLESHOOTING.....	24
TECHNICAL ASSISTANCE.....	25
HYDROID CONTROLLER SPECIFICATIONS AND INSTRUCTIONS.....	26
FRONT PANEL CONTROLS AND INDICATORS.....	26
SYSTEM OPERATION.....	27
GENERAL OPERATION.....	27
DISPLAY AND STATUS INDICATORS.....	27
RO START DELAY (-).....	27
PRESSURE FAULT (PF).....	27
PRESSURE FAULT (PF) RETRY.....	28
TANK FULL (FUL).....	28
PRE-TREAT LOCKOUT (PL).....	28
WATER QUALITY DISPLAY.....	28
MEMBRANE FLUSH.....	28
SYSTEM ACCESSORY.....	29
SYSTEM WARRANTY.....	30
WARRANTY TERMS.....	30
WARRANTY COMMENCEMENT DATE.....	30
WARRANTY SERVICE.....	30
VOIDABILITY OF WARRANTY.....	31

QUICK CONNECT FITTINGS

CONNECTING QUICK CONNECT FITTINGS:

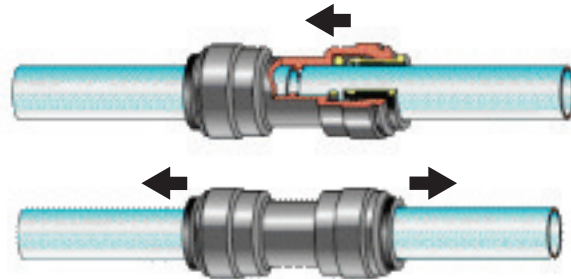

Push tube firmly into the fitting, all the way to tube stop. The collet (gripper) has stainless steel teeth which hold the pipe firmly in position whilst the O-ring provides a permanent leak proof seal. Pull tubing to check for security. If some tube pulls out then push all the way in again until it stops.

It is good practice to test the system prior to leaving site and/or before use.

Disconnecting Quick Connect Fittings:

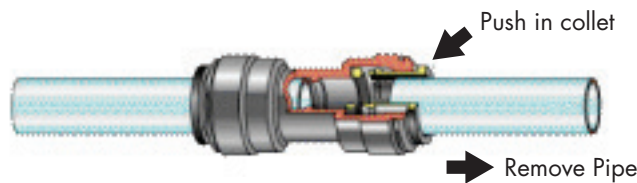

Ensure system is depressurized by turning off source water before removing fittings. Push in the collet evenly toward the fitting. With the collet held in this position the tube can be removed by simply pulling. You can use a collet release tool (available from your dealer) or small crescent wrench. The fitting can then be re-used. If the tube has been removed several times you may see score marks on the ends. This can lead to leaks so cut the end off the tubing totally square with a sharp blade using care.

INTRODUCTION

The Hydroid Reverse Osmosis System is a state-of-the-art, versatile system for treating tap water supplies with minimal set-up, low energy consumption, low maintenance, and reduced operating costs. The Hydroid system features a robust, innovative design that requires no adjustments in the event of feed water quality or temperature variations. Your Hydroid system is a durable piece of equipment which, with proper care, will last for many years. Standard features include CONCENTRATE (drain) water recycle loop, PRODUCT (purified water) blend valve, PRODUCT (purified water) TDS monitoring, preset pump, CONCENTRATE (drain) water and CONCENTRATE (drain) water recycle flows. Hydroid series systems feature high quality parts and components for enhanced performance and reliability including proprietary Membrane Elements, glycerin filled pressure gauges, acrylic flow meters, Carbon pre-filter, Grundfos pump, blending valve, and computer controller.

This User Manual outlines installation, operation, maintenance and troubleshooting details vital for the sustained performance of your system.

PRIOR TO OPERATING OR SERVICING THE REVERSE OSMOSIS SYSTEM, THIS USER MANUAL MUST BE READ AND FULLY UNDERSTOOD. KEEP THIS AND OTHER ASSOCIATED INFORMATION NEAR THE SYSTEM FOR FUTURE REFERENCE.

IN ORDER TO MAINTAIN THE MANUFACTURER'S WARRANTY, AN OPERATING LOG MUST BE MAINTAINED. COPIES WILL NEED TO BE SENT TO HYDROLOGIC FOR REVIEW IN THE EVENT OF A WARRANTY COVERAGE ISSUE.

SAFETY

PRECAUTIONARY STATEMENTS



DO NOT USE WHERE THE WATER IS MICROBIOLOGICALLY UNSAFE OR OF UNKNOWN QUALITY WITHOUT ADEQUATE DISINFECTION BEFORE OR AFTER THE SYSTEM.



ALWAYS TURN OFF THE UNIT, SHUT OFF THE FEEDWATER, RELIEVE PRESSURE, AND DISCONNECT THE ELECTRICAL POWER BEFORE WORKING ON THE UNIT.



PRE-TREATMENT MUST BE SUFFICIENT TO ELIMINATE CHEMICALS, ORGANICS OR INORGANICS THAT COULD DAMAGE THE MEMBRANE MATERIAL.



DO NOT OPERATE THE SYSTEM WITH INSUFFICIENT FEED FLOW. NEVER ALLOW THE PUMP TO RUN DRY.



NEVER ALLOW THE UNIT TO FREEZE OR OPERATE WITH A FEEDWATER TEMPERATURE ABOVE 85°F.



DO NOT PERMIT CHLORINE TO BE PRESENT IN THE FEED WATER.



DO NOT SHUT DOWN THE SYSTEM FOR EXTENDED PERIODS. IT IS BEST TO RUN THE SYSTEM AS MUCH AS POSSIBLE ON A CONTINUOUS BASIS.



ELEVATED LEVELS OF SEDIMENT IN FEED WATER WILL LEAD TO SHORTER LIFE FOR CARBON FILTER

HYDROID SCHEMATICS

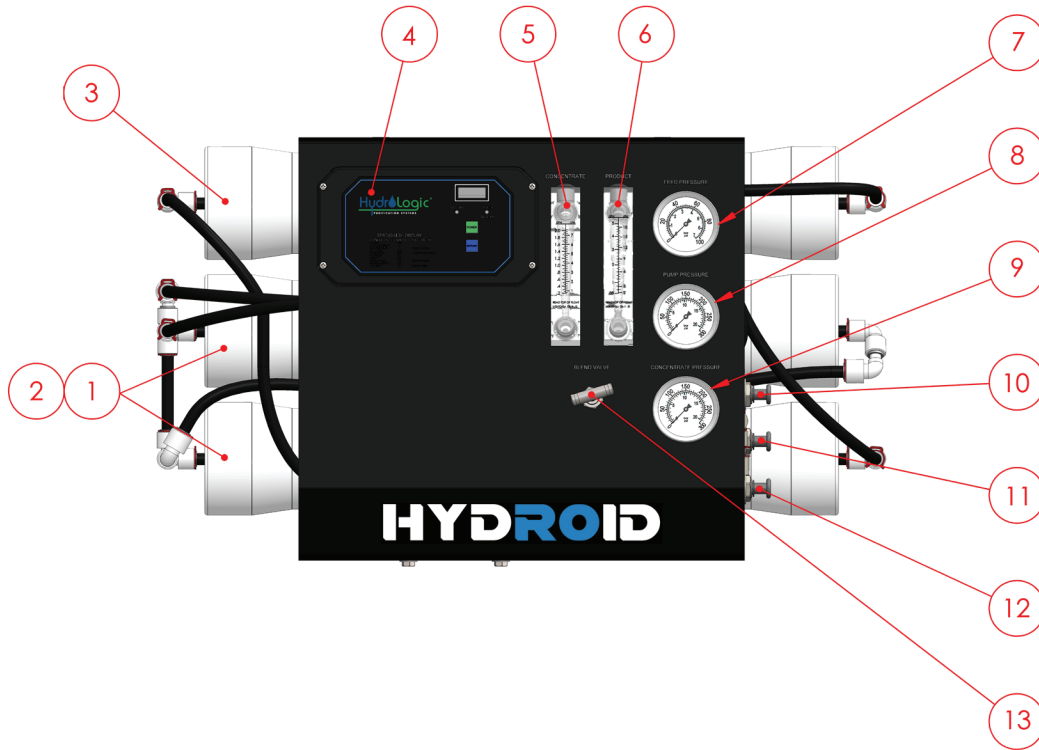

ITEM NUMBER	DESCRIPTION
1,2	MEMBRANE: HL 11590
3	CARBON FILTER: HL 11591
4	CONTROLLER: MICROPROCESSOR W/TDS MONITOR
5	FLOW METER: CONCENTRATE (DRAIN)
6	FLOW METER: PRODUCT (PURIFIED WATER)
7	INLET PRESSURE FEED GAUGE
8	PUMP PRESSURE GAUGE
9	CONCENTRATE PRESSURE GAUGE
10	PRODUCT ½" QC FITTING (PURIFIED WATER)
11	CONCENTRATE ½" QC FITTING (DRAIN)
12	INLET ½" QC FITTING (FEED)
13	BLENDING VALVE (BLEND VALVE)

HYDROID SCHEMATICS (CONTINUED)

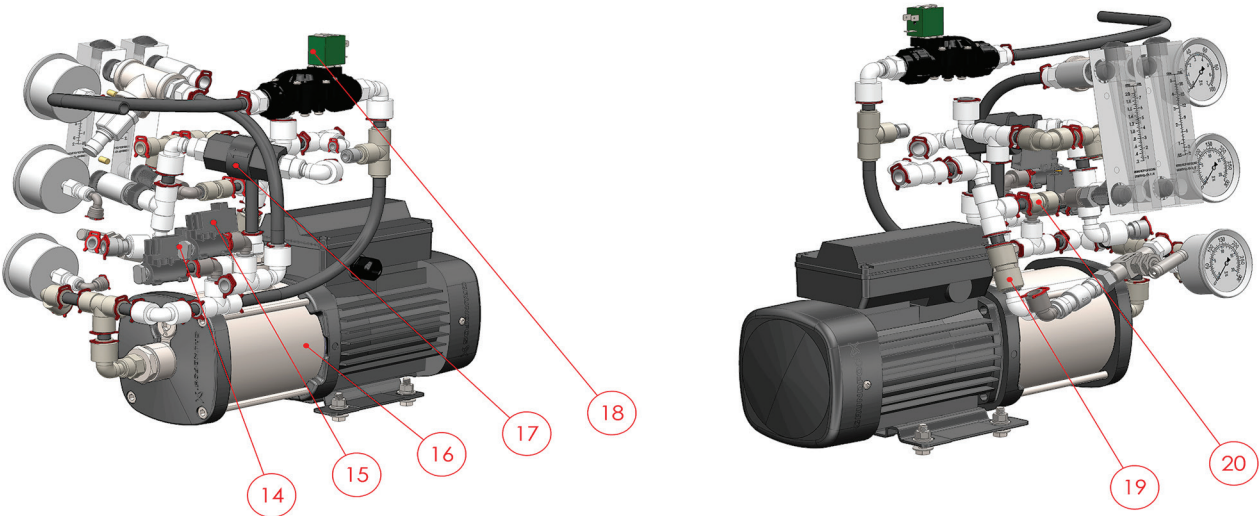

ITEM NUMBER	DESCRIPTION
14	HIGH PRESSURE SWITCH: 40–60 PSI (HIGH PRESSURE SWITCH)
15	LOW PRESSURE SWITCH: 0–20 PSI (LOW PRESSURE SWITCH)
16	¾ HP, GRUNDFOS PUMP, 110V, 60HZ, 1PH, 10.6 AMPS
17	CHECK VALVE
18	2-WAY, SOLENOID VALVE, 110V, N/C
19	FLOW CONTROL CONNECTOR (RECYCLE FLOW RESTRICTOR)
20	FLOW CONTROL CONNECTOR (CONCENTRATE (DRAIN) FLOW RESTRICTOR)

COMPONENTS AND FILTRATION DESCRIPTION

CONTROLLER

The Hydroid microprocessor controller includes numerous standard features such as pressure switch controls, TDS/conductivity monitor, pre-treatment lock out, float switch controls, and flush valve control. The controller displays system status, fault sensors, and input TDS status on an easy-to-read 3-digit LED display.

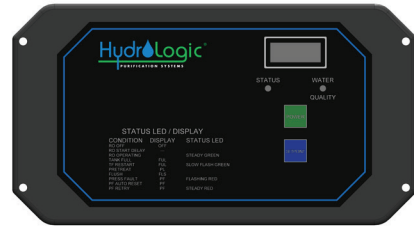

PREFILTRATION

Hydroid systems come standard with a carbon filter. Change the filter when 75,000 gallons of purified water has been produced. Or, a 15 or more psi drop occurs on feed gauge, when compared to the initial startup reading. For example, if the FEED Pressure Gauge reads 60 psi (you will need to log initial pressure after step 10 on page 15 has been performed) the filter should be changed when the FEED Pressure Gauge is 45 psi or below.



BE SURE TO LOG ALL DATA UPON STARTUP (PG 22)



THE SYSTEM MUST BE OPERATED ON FILTERED WATER ONLY

FEED PRESSURE GAUGE

This gauge measures the water pressure when it exits the filter.

LOW PRESSURE SWITCH

The low pressure switch shuts off the system when the FEED water pressure drops below 15 psi, preventing damage to the pump. The system restarts automatically when there is a constant pressure of 40 psi or more.

COMPONENTS AND FILTRATION DESCRIPTION (CONTINUED)



IF THE SYSTEM PRESSURE IS FLUCTUATING, AND THE SYSTEM CYCLES OFF AND ON, TURN THE SYSTEM OFF AND ENSURE THAT PROPER FEED WATER FLOW AND PRESSURE ARE BEING SUPPLIED TO THE SYSTEM.

PUMP

The Hydroid system uses a multi-stage centrifugal stainless-steel pump. If any damage occurs to your system's pump, a rebuild kit is available. Contact HydroLogic for parts and warranty.

PUMP PRESSURE GAUGE

The pump pressure gauge measures the pressure of the water as it enters the first membrane in the system.

MEMBRANES

The Hydroid system comes with USA made, Commercial-Grade Hi-Flow Membrane Elements. Membranes separate impurities from water through the reverse osmosis process.

CONCENTRATE PRESSURE GAUGE (DRAIN)

The CONCENTRATE pressure gauge (drain) measures the pressure of the CONCENTRATE (drain water) as it exits the last Membrane of the system. Subtracting the CONCENTRATE pressure from the pump pressure will give the pressure drop across the Membranes.

CONCENTRATE FLOW METER (DRAIN)

The CONCENTRATE flow meter (drain) measures the amount of wastewater the system is sending to drain as gallons/liters per minute.

PRODUCT FLOW METER (PURIFIED WATER)

The PRODUCT flow meter (purified water) measures the amount of PRODUCT water (purified water) the system is producing as gallons/liters per minute.

BLEND VALVE

Allows for a mixture of post-carbon treated water into the RO's PRODUCT water (purified water) to achieve desirable PRODUCT (purified water) TDS and higher flow rates.



IF THE SYSTEM HAS AN ANTI-SCALANT FILTER, THE BLEND VALVE MUST REMAIN CLOSED. THIS IS TO AVOID INGESTION OF ANY CHEMICALS AND CAN BE TOXIC FOR AGRICULTURAL USE.

HL 11595

FEED WATER AND OPERATION SPECIFICATIONS

Nothing has a greater effect on a reverse osmosis system than the feed water quality. If your system is altered at the site of operation or if the feed water conditions change, please contact HydroLogic. Before starting the RO system, it is strongly suggested to obtain an up-to-date water analysis of the water to be treated.



IT IS VERY IMPORTANT TO MEET THE MINIMUM FEED WATER AND OPERATING REQUIREMENTS OUTLINED IN THIS MANUAL. FAILURE TO DO SO WILL CAUSE DAMAGE OR FAILURE OF THE SYSTEM COMPONENTS AND MEMBRANES. DAMAGE TO THE SYSTEM DUE TO OPERATION OUTSIDE OF THE SPECIFICATIONS OUTLINED IN THIS MANUAL WILL VOID THE MANUFACTURER'S WARRANTY. CHECK YOUR FEED WATER CHEMISTRY AND, IF NECESSARY, CONSULT WITH HYDROLOGIC BEFORE START UP OF THE SYSTEM.

OPERATING LIMITS*

Optimal Operating Temperature, °F	77	Maximum Turbidity, NTU	1
Maximum Feed Temperature, °F	85	Maximum Free Chlorine, ppm	0
Minimum Temperature, °F	40	Maximum TDS, ppm	1,000 †
Maximum Ambient Temperature, °F	120	Maximum Hardness, gpg	10
Minimum Ambient Temperature, °F	40	Maximum pH (continuous)	10
Maximum Feed Pressure, psi	85	Minimum pH (continuous)	4
Minimum Feed Pressure, psi	40	Maximum pH (cleaning 30 minutes)	12
Maximum Operating Pressure, psi	150	Minimum pH (cleaning 30 minutes)	2
Maximum SDI Rating	<3		
† Low temperatures and feedwater quality, such as high TDS levels will significantly affect the systems production capabilities and performance. *If any of the feed water parameters are not within the given limits, consult HydroLogic for assistance.			



HIGHER TDS AND/OR LOWER TEMPERATURES WILL REDUCE THE SYSTEM'S PRODUCTION.

DESIGN BASIS AND DESIGN NOTES

Design	
Configuration	Single Pass
Feedwater Source	TDS < 1000
System Recovery with Recycle	66+% ††††
System Pressure	100 PSI †††
Rejection and Flow Rates†††	
Nominal Salt Rejection	95%
PRODUCT Flow Rate (purified water)	2.0+ GPM ††††
CONCENTRATE Flow Rate (drain)	0.80 GPM
CONCENTRATE Recycle Flow Rate (drain)	2.20 GPM
Connections	
Inlet Fitting (feed)	½" QC
PRODUCT Fitting (purified water)	½" QC
CONCENTRATE Fitting (drain)	½" QC
Carbon Filters	
Carbon Filter per Vessel	1
Carbon Filter Quantity	1
Carbon Filter Part #	HL 11591
Membranes	
Membranes per Vessel	1
Membrane Quantity	2
Membrane Part #	HL 11590
Pumps	
Pump Type	Multi-Stage Centrifugal
Motor Horsepower	¾ HP
RPM at 60HZ	3450
System Electrical	
Controller	Microprocessor
High Voltage Service + Amp Draw	120V, 1PH, 60 HZ ,10.6A
System Dimensions	
Approximate Dimensions †† (L x W X H)	29.5" X 18.5" X 18"
Approximate Weight (Wet System)	110 lbs.
††Does not include operating space requirements.	
†††System Pressure is variable due to water conditions. PRODUCT (purified water) flow will increase at a higher temperature and decrease at a lower temperature (see TCF Table on pg. 23).	
†††† PRODUCT (purified water) flow and maximum recovery rates are based on feedwater conditions as stated above.	

SYSTEM INSTALLATION OVERVIEW

CHOOSING A LOCATION

When choosing a location to install the system, select an area with enough room to remove the membranes and easily access components and connections. Make sure there is enough room for service to be performed on the system. Take into consideration where your electrical power supply is located and where the nearest drain is located. Do not install system in direct sunlight, high intensity lights or subject the system to temperature extremes (see operating limits chart) and/or excess humidity. The Hydroid system should be secured in compliance with state and local regulations.

INLET ½" QC FITTING (FEED)

Locate the ½" QC fitting on the right side of the system labeled "FEED." Attach the inlet tubing to the system.



FEED LINE MUST BE AT LEAST ½" (PROVIDED).



SYSTEM REQUIRES A CONTINUOUS FLOW OF WATER WITH A MINIMUM FEED PRESSURE OF 40 PSI, NOT TO EXCEED 85 PSI.



PRODUCT ½" QC FITTING (PURIFIED WATER)

Locate the ½" QC fitting on the right side of the system labeled "PRODUCT." Attach product tubing to system.



ENSURE THAT THE PRODUCT (PURIFIED WATER) CAN FLOW FREELY WITH NO BACK PRESSURE. BACK PRESSURE CAN CAUSE IRREVERSIBLE DAMAGE TO THE MEMBRANES.



THE PH OF THE REVERSE OSMOSIS PRODUCT WATER (PURIFIED WATER) WILL TYPICALLY BE 1 OR 2 PH UNITS LOWER THAN THE FEEDWATER PH.

SYSTEM INSTALLATION OVERVIEW (CONTINUED)

CONCENTRATE 1/2" QC FITTING (DRAIN)

Locate the 1/2" port on the right side of the system labeled "CONCENTRATE". Run the concentrate line to an open drain in a free and unrestricted manner (no back pressure).



ANY RESTRICTIONS OR BLOCKAGE IN THE DRAIN LINE CAN CAUSE BACK PRESSURE, WHICH WILL INCREASE THE SYSTEM'S OPERATING PRESSURE. THIS CAN RESULT IN DAMAGE TO THE SYSTEM'S MEMBRANES AND COMPONENTS.

ELECTRICAL

The Hydroid system is 110V, 60 Hertz Single Phase, 10.6 amps, and is equipped with an 8' electrical cord.

Ensure that the electrical circuit supplying the system is compatible with the requirements of the Hydroid.



TO REDUCE THE RISK OF ELECTRICAL SHOCK, THE INCOMING POWER SUPPLY MUST BE A GFI OUTLET.



IT'S RECOMMENDED THAT THE SYSTEM HAVE A DEDICATED POWER SOURCE.

TANK

Hydroid systems may be connected to a bladder tank or a storage tank with a float valve. The float valve shuts off the system when the tank is full and opens when the water level in the tank drops. Bladder tanks and storage tanks with float valves can be obtained by your local dealer or distributor. If a storage tank with float valve is to be used, install it at this time.

SYSTEM PURGING / INITIAL START-UP

LEAVE THE SYSTEM UNPLUGGED FROM POWER UNTIL STEP 6

1. Remove dust caps and short tubes from all ports: PRODUCT (purified water—blue tubing), CONCENTRATE (drain—black tubing), and FEED (inlet—white tubing). Install the provided white tubing to FEED port for inlet water. Install a red clip (included in system parts bag) on FEED port to lock tubing in place. Install other end of white FEED line to tap/source water, or use included garden hose connector (included in system parts bag).



2. The open end of the pre-installed ½" black tubing labeled "Flush" (B) goes to a drain. Now you can begin to slowly turn on the water supply and flush the dust from the carbon filter, until water stream is clear (approx. 5 min).
3. Turn OFF the water supply and immediately turn it ON again, to create an agitated flush effect in the carbon cartridge. Repeat this process 3–4 times or until there are no carbon fines in the water stream.
4. Install System Tubing for Normal Operation: Remove red clip (A), disconnect ½" black Flush tubing (B) and then push system tubing (C) into carbon filter port. Replace the red clip to lock system tubing to carbon filter, shown in the picture below. **For filter replacements, reverse this step.**

IMPORTANT: Keep black Flush tubing for future carbon filter flush procedures.

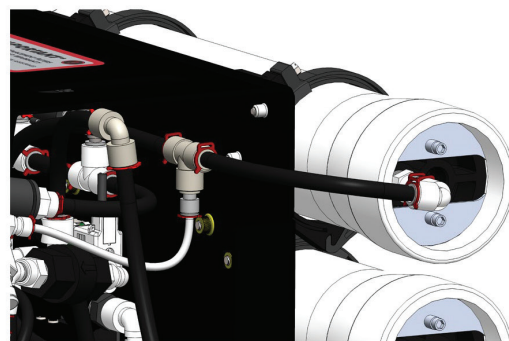
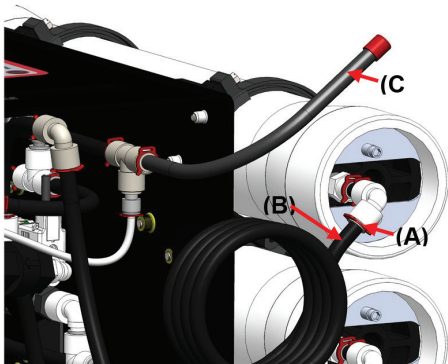

SYSTEM PURGING / INITIAL STARTUP (CONTINUED)

LEAVE THE SYSTEM UNPLUGGED FROM POWER UNTIL STEP 6

5. Connect Provided Tubing: PRODUCT (purified water—blue tubing) and CONCENTRATE (drain—black tubing) to their ports; re-direct the open ends of both the PRODUCT (purified water—blue tubing) and CONCENTRATE (wastewater—black tubing) to drain. Install the red clips included in systems parts bag. Fully close the blend valve by turning it clockwise.

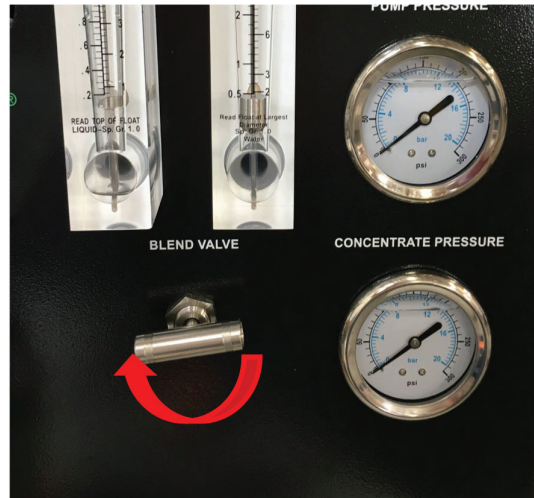
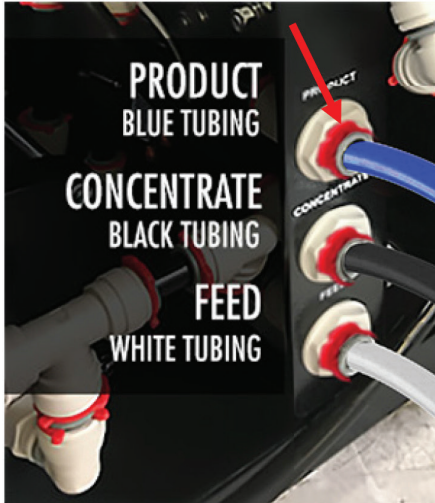

6. Activate the system purge feature by pressing and holding the Power button on the controller for 5 seconds. The inlet valve will open and the system will flush continuously.
7. Let the system purge until no bubbles appear in CONCENTRATE (drain water—black tubing) flow meter (approx. 15 min).
8. When the Hydroid system has been purged of air, press the power button momentarily to turn off the purge feature. The Hydroid will turn off.
9. Inspect the system for leaks. If no leaks are apparent, the next step is to flush the Membrane Elements.
10. Turn system on and allow the system to run uninterrupted for at least 30 minutes to flush the Membrane Elements.
11. After 30 minutes, shut down the system and re-direct PRODUCT (purified water—blue tubing) to holding tank. Your system is now ready for normal operation.

OPERATING DOs AND DON'TS

DO

- Change the carbon filter regularly (75,000 gallons)
- Monitor the system and keep a regular log (weekly)
- Run the system at least every 72 hours for one hour or more
- Always feed the pump with filtered water



DON'T

- Permit chlorine to enter the feed water (change carbon filter every 75,000 gallons)
- Shut down the system for extended periods (see manual page 23)
- Operate the system with insufficient feed flow or pressure
- Operate the pump dry



TO MAINTAIN PROPER PRESSURE, MAXIMUM HORIZONTAL TUBING DISTANCE TO TANK STORAGE IS 50'. IMPORTANT! FOR EVERY 5' VERTICAL HEIGHT, YOU NEED TO SHORTEN TUBING BY 10' OF HORIZONTAL LENGTH. **EXAMPLE: IF TUBING NEEDS TO BE INSTALLED 10' OFF THE GROUND, TOTAL HORIZONTAL LENGTH MAY NOT EXCEED 30FT. IF LENGTH EXCEEDS SPECIFICATIONS, PLEASE CONTACT HYDROLOGIC 888-426-5644.**



USING THE REVERSE OSMOSIS SYSTEM OPERATION LOG PROVIDED ON PAGE 22 OF THE USER MANUAL, RECORD YOUR SYSTEM'S READING DAILY FOR A WEEK. AFTER A WEEK, RECORD THE READINGS AT A MINIMUM OF ONCE A WEEK. IT IS SUGGESTED TO MAKE SEVERAL COPIES OF THIS SHEET FOR FUTURE USE BEFORE RECORDING INITIAL READINGS. KEEPING AN OPERATION LOG IS IMPORTANT TO TROUBLESHOOT POSSIBLE TECHNICAL ISSUES.



IF THE SYSTEM HAS AN ANTISCALANT FILTER (OPTIONAL **HL 11595**), AND IF THE PRODUCT WATER (PURIFIED WATER) IS USED AS POTABLE WATER, THE BLEND VALVE MUST REMAIN CLOSED. THIS IS TO AVOID INGESTION OF ANY CHEMICALS.

FILTER REMOVAL AND INSTALLATION



ALL PRESSURE GAUGES MUST READ ZERO BEFORE BEGINNING THIS PROCEDURE. TURN THE SYSTEM OFF, DISCONNECT THE POWER, AND BLEED ALL WATER PRESSURE FROM THE SYSTEM.



DO NOT USE PETROLEUM BASED LUBRICANT.

1. Perform this procedure one filter housing at a time to preserve the correct connections as you replace the filters
2. Select the filter housing to be replaced
3. Remove red locking clip
4. Disconnect the fittings from the filter housing by simultaneously:
 - a. Pushing the grey collet toward the filter housing
 - b. Pulling the tube from the collet

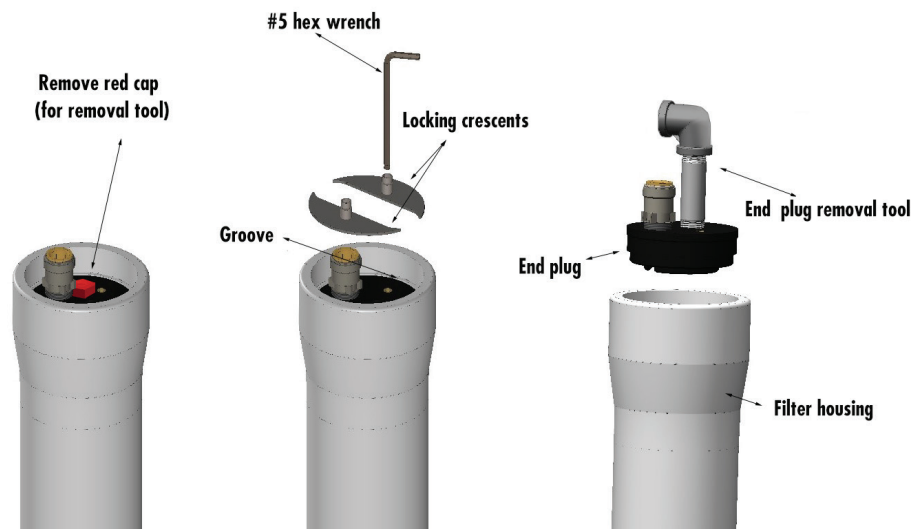

5. Unscrew and remove the two locking crescents using a #5 hex wrench. Remove red cap and thread the removal tool into the end plug (center hole) to hand-tightness. Pull the removal tool outward to remove the end plug from filter housing. Set the end plug aside in a clean area where the O-ring will not pick up dirt or debris
6. Pay close attention to the flow direction arrows on the filter housings when installing new filters

FILTER REMOVAL AND INSTALLATION (CONTINUED)

7. Remove the old filter from the filter housing. Long nose pliers may be necessary to pull the old filter out of the filter housing. A slight rocking motion or forceful tug may be required to remove the filter from the filter housing
8. Lubricate the brine seal and O-rings on the new filters with provided silicon lubricant packet. Do not use a petroleum-based lubricant
9. Apply the same lubricant to the inside of the housing below the groove for the locking crescents, where the filter brine seal will make contact when inserted
10. Install filter with brine seal location depicted in the flow chart below

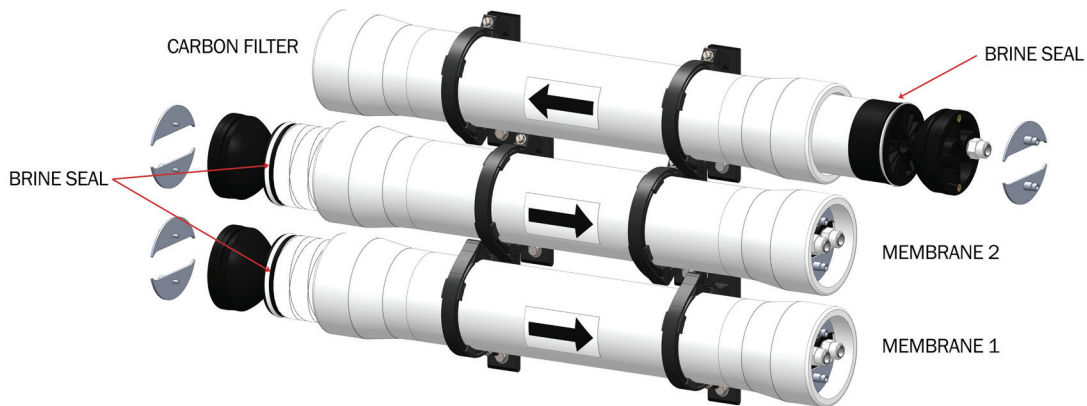

11. The filter should stop when fully seated in the bottom end plug
12. Re-install the end plugs by gently and evenly pushing them onto the filter housing. Ensure that you do not pinch or fatigue any O-rings while re-installing the end plug. Push the end plug in until it is seated just below the groove for the locking crescents, as shown on previous page.
13. Reinstall the locking crescents and securely tighten the screws. **DO NOT OVER TIGHTEN.**
14. Reconnect any fittings that may have been disconnected when the filter housings were disassembled. If changing carbon filter, go to page 14, step 4 (filter flush). If replacing membrane, continue to step 15.
15. To start up the system, please refer to the System Purging/Initial Start-Up section of this User's Manual (pg. 15).



MAKE SURE THE O-RINGS AND END PLUGS ARE FREE FROM DIRT AND DEBRIS BEFORE RE-INSTALLING. DIRT AND OTHER FOREIGN MATERIALS LEFT ON THE END PLUGS CAN CAUSE LEAKS AND/OR DAMAGE THE MEMBRANES AND CAUSE CONTAMINATION.

MEMBRANE ELEMENTS

Hydroid Compact Commercial Reverse Osmosis Systems are equipped with Hydroid Series Commercial-Grade, Hi-Flow Membrane Elements. Hydroid Membrane Element performance characteristics are listed below.

- Membrane Type: Polyamide Thin—Film Composite
- Maximum Operating Temperature: 85°F (43°C)
- Maximum Operating Pressure: 150 psi (10 bar)
- pH Range, Continuous Operation*: 2–11
- pH Range, Short Term Cleaning (30 Min.): 1–13
- Maximum Feed Silt Density Index (SDI): ≤3
- Chlorine Tolerance: 0 ppm
- Maximum Feed Flow Rate (gpm): 4.0" = 5

*Maximum temperature for continuous operations above pH10 is 95°F (35°C)

Product Specifications				
Part Number	Description	Applied Pressure psi/bar	PRODUCT Flow Rate gpd/ gph	Nominal Salt Rejection (%)
HL 11590	MEMBRANE	100 / 5.52	3,000 / 125	95
Warranty Evaluation Test Conditions: PRODUCT (purified water) flow and salt rejection based on the following test conditions—550 ppm, filtered and dechlorinated municipal tap water, 77°F / 25°C, 15% recovery and the specified operating pressure. Minimum salt rejection is 95%+. PRODUCT (purified water) flows for warranty evaluation may vary +/-20%. Maximum pressure drops at 13 psi / 0.9 bar.				

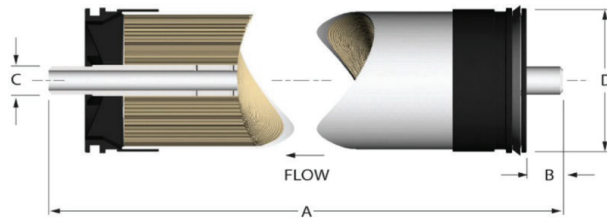

Under certain conditions, the presence of free chlorine, chloramines and other oxidizing agents will cause premature membrane failure. Since oxidation damage is not covered under warranty, the manufacturer recommends removing all oxidizing agents by pretreatment prior to membrane exposure. Please contact the HydroLogic for more information.

Do not use the initial PRODUCT (purified water) for drinking water or food preparation. Keep elements moist at all times after initial wetting. To prevent biological growth during prolonged system shutdowns, it is recommended that membrane elements be immersed in a preservative solution. Rinse out the preservative before use. For membrane warranty details, contact HydroLogic for more information.

If operating limits and guidelines given in this PRODUCT (purified water) specification sheet are not strictly followed, the warranty will be null and void. The customer is fully responsible for the effects of incompatible chemicals and lubricants on elements. Use of any such chemicals or lubricants will void the warranty. These membranes may be subject to drinking water application restrictions in some countries: check the application status before use and sale. The use of this PRODUCT (purified water) in and of itself does not guarantee the removal of cysts and pathogens from water. Effective cyst and pathogen reduction are dependent on the complete system (solution) design and the operation and maintenance of the system.

No freedom from infringement of any patent owned by the manufacturer or others is to be inferred. Because use conditions and applicable laws may differ from one location to another and may change with time, Customer is responsible for determining whether PRODUCT (purified water) and the information in this document are appropriate for customer's use and for ensuring that customer's workplace and disposal practices are in compliance with applicable laws and other governmental enactments. The claims made may not have been approved for use in all countries. The manufacturer assumes no obligation or liability for the information in this document. **NO WARRANTIES ARE GIVEN; ALL IMPLIED WARRANTIES OF MERCHANTABILITY OR FITNESS FOR A PARTICULAR PURPOSE ARE EXPRESSLY EXCLUDED.**

REJECTION, RECOVERY AND FLOW RATES

MEMBRANE PERFORMANCE

Hydroid reverse osmosis systems are designed to produce 3,000 GPD of PRODUCT water (purified water) at a minimum of 98%+ rejection under the proper conditions.

REJECTION

The amount of total dissolved solids (TDS) rejected by the membrane is expressed as a percentage. Hydroid reverse osmosis systems are designed to reject up to 98%+ NaCl depending on feed water chemistry. A 98%+ rejection rate means that 98% of total dissolved solids do not pass through the membrane. To calculate the percent of rejection, use the following formula:

Percent of Rejection = $[(\text{FEED (inlet) TDS} - \text{PRODUCT (purified water) TDS}) / \text{Feed TDS}] \times 100$

Example: $[(550 \text{ PPM FEED (inlet) water TDS} - 11 \text{ PPM PRODUCT (purified water) TDS}) / 550] \times 100 = 98\%+$

ALL TDS FIGURES MUST BE EXPRESSED IN THE SAME UNITS, TYPICALLY PARTS PER MILLION (PPM) OR MILLIGRAMS PER LITER (MG/L).

RECOVERY

The amount of PRODUCT water (purified water) recovered for use is expressed as a percentage. To calculate percent of recovery, use the following formula:

Percent of Recovery = $(\text{PRODUCT (purified water) Water Flow Rate} / \text{FEED (inlet) water flow rate}) \times 100$

For Example, if the Hydroid makes 2.0 GPM PRODUCT (purified water) and has a FEED (inlet) flow of 2.66 GPM.

$(2.0 \text{ GPM PRODUCT (purified water) flow} / 2.66 \text{ GPM FEED (inlet) flow}) \times 100 = 75\%$

ALL FLOW RATES MUST BE EXPRESSED IN THE SAME UNITS, TYPICALLY GALLONS PER MINUTE (GPM).



THE MEMBRANES MUST BE FLUSHED FOR AT LEAST 30 MINUTES. DISCARD ALL OF THE PRODUCT (PURIFIED WATER) THAT IS PRODUCED DURING THE FLUSH PERIOD.

TEMPERATURE CORRECTION FACTORS FOR MEMBRANES

A membrane’s stated PRODUCT (purified water) production rate is based on a water temperature of 77°F. Temperature above or below 77°F will increase or decrease the membrane’s production rate.

Find the temperature correction factor (TCF) for your water temperature on the table located below. Divide the rated PRODUCT (purified water) flow (The equation can be found on Page 20 under “Recovery”) by the temperature correction factor. The result is the nominal PRODUCT (purified water) flow rate the system should achieve at actual water temperature. PRODUCT (purified water) flow should be within 20% of the rated production, after correcting the feed water temperatures above or below 77°F. Check your PRODUCT (purified water) flow meter to determine the flow rate.

Example:

Rated PRODUCT (purified water) Flowrate = 2 GPM @ 77°F

Actual Water Temperature = 55°F

Temperature Correction Factor @ 55°F = 1.541

PRODUCT (purified water) Flowrate @ 55°F = 2 GPM ÷ 1.541 = 1.297 GPM

Find the temperature correction factor (TCF) from the table below. Divide the rated PRODUCT (purified water) flow at 77°F by the temperature correction factor. The result is the PRODUCT (purified water) flow at the desired temperature (see example on previous page).

Feed Water Temperature		Temperature Conversion Factor	Feed Water Temperature		Temperature Conversion Factor
°C	°F		°C	°F	
10.0	50.0	1.711	20.0	68.0	1.189
10.5	50.9	1.679	20.5	68.9	1.168
11.0	51.8	1.648	21.0	69.8	1.148
11.5	52.7	1.588	21.5	70.7	1.128
12.0	53.6	1.558	22.0	71.6	1.109
12.5	54.5	1.588	22.5	72.5	1.090
13.0	55.4	1.530	23.0	73.4	1.071
13.5	56.3	1.502	23.5	74.3	1.053
14.0	57.2	1.475	24.0	75.2	1.035
14.5	58.1	1.448	24.5	76.1	1.017
15.0	59.0	1.422	25.0	77.0	1.000
15.5	59.9	1.396	25.5	77.9	0.985
16.0	60.8	1.371	26.0	78.8	0.971
16.5	61.7	1.347	26.5	79.7	0.957
17.0	62.6	1.323	27.0	80.6	0.943
17.5	63.5	1.299	27.5	81.5	0.929
18.0	64.4	1.276	28.0	82.4	0.915
18.5	65.3	1.254	28.5	83.3	0.902
19.0	66.2	1.232	29.0	84.2	0.889
19.5	67.1	1.210	29.5	85.1	0.877

Disclaimer: These numbers are to be used as estimates.

Many other real-world factors like water pressure, water quality, and membrane scaling also influence membrane performance.

OPERATING LOG

- Company Name _____

- Day of Start Up _____

- Location _____

- Date of Last Cleaning _____

- Week Of _____

- System Serial No. _____

Date					
Time					
Hour of Operation					
Filter Inlet Pressure (PSI)					
Filter Outlet Pressure (PSI)					
Concentrate Pressure (PSI)					
Pump Discharge Pressure (PSI)					
Feed Flow (GPM)					
Permeate Flow (GPM)					
Concentrate Flow (GPM)					
Recycle Flow (GPM)					
Recovery %					
Feed Temperature					
Feed TDS (PPM)					
Permeate TDS (PPM)					
Rejection %					
Feed pH					
Permeate pH					
Scale Inhibitor Feed (PPM)					
Iron (mg/L)					
Free Chlorine (mg/L)					
Hardness (GPG CaCO ₃)					

PREPARING UNIT FOR STORAGE



ALL PRESSURE GAUGES MUST READ ZERO BEFORE BEGINNING THESE PROCEDURES. TURN THE SYSTEM OFF, DISCONNECT THE POWER, AND BLEED ALL WATER PRESSURE FROM THE SYSTEM.

PREPARING THE SYSTEM FOR STORAGE

1. We recommend NOT leaving the system idle for more than 72 hours.
2. If the period of non-operation is more than 72 hours, we recommend removing the Membranes, sealing them in a plastic bag, and storing in a refrigerator.
3. If storing, the Membrane's performance cannot be guaranteed.

During the shut-down period, the area must be kept frost-free, or the ambient temperature must not exceed 120°F (48.8°C) ambient.

TROUBLESHOOTING

SYMPTOMS	POSSIBLE CAUSES	CORRECTIVE ACTION
Low Inlet Pressure	Low supply pressure	Increase inlet pressure
	Filter is plugged	Change filter
	Solenoid valve malfunction	Inspect / replace solenoid valve and/or coil
	Leaks	Fix any visible leaks
Low PRODUCT (purified water) Flow	Cold feedwater	See temperature correction sheet
	Low operating pressure	See low inlet pressure
	Fouled or scaled membrane	Replace membranes
	Filter is plugged	Change filter
High PRODUCT (purified water) Flow	Damaged or oxidized membrane	Replace membranes
	Exceeding maximum feedwater temperature	See temperature correction sheet
Poor PRODUCT (purified water) Quality	Low operating pressure	See low inlet pressure
	Damaged or oxidized membrane	Replace membranes
System Inoperative	Fuse	If water quality display not lit, check fuse F2 below transformer
	Wiring to controller	If fuse is ok, check power terminals to L1 and L2 with A voltmeter. If no power, rewiring may be required.
	Defective controller board	If power to terminals is OK, the board may be defective and should be replaced.
Inlet Valve Will Not Operate	Controller is off	Turn controller on
	Fuse	If shutdown conditions are active and inlet LED, L2 is lit, check fuse F1.
	Defective controller board	If shutdown conditions are active and inlet LED L2 is NOT lit, board may need to be replaced.
	Wiring to valve	Use voltmeter to check inlet terminals for power to controller board. If board has power, check valve and valve wiring.
RO Pump Will Not Operate	Controller is off	Turn controller on
	Fuse	If shutdown conditions are active and RO LED L1 is lit, check fuse F1.
	Defective controller board	If shutdown conditions are active and inlet LED L1 is NOT lit, board may need to be replaced.
	Wiring to pump	Use voltmeter to check inlet terminals for power to controller board. If board has power, pump motor and motor wiring.

TECHNICAL ASSISTANCE

If technical assistance is required,
contact HydroLogic directly:
Toll-free 888-426-5644

Prior to making the call, have the
following information available:

- System installation date
- Serial number
- Daily log sheets
- Current operating parameters (e.g., flow, operating pressures, pH, etc.)
- Detailed description of the problem

HYDROID CONTROLLER SPECIFICATIONS AND INSTRUCTIONS

INTRODUCTION

The Hydroid controller is a microprocessor-controlled system that can monitor pressure and level switches. The TDS monitor/controller with adjustable limit is an integral part of the Hydroid controller. The Hydroid controller displays system status and sensor and switch input status using a status LED and a 3-digit LED display.

Front Panel: Overlay with LED window, status LED, water quality LED, and power

Switch Inputs, Dry Contact:

Pressure fault
Pretreat lockout
Tank full

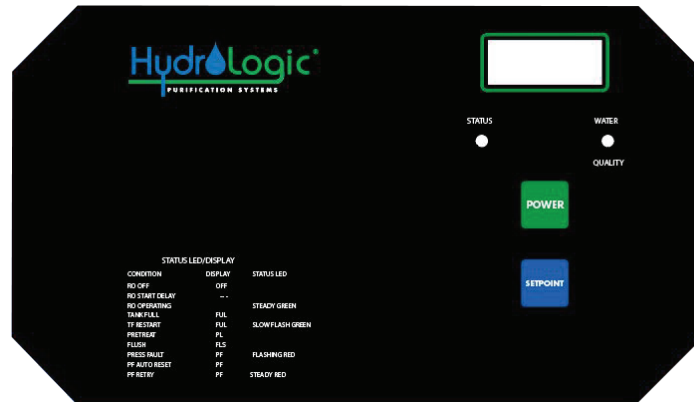

FRONT PANEL CONTROLS AND INDICATORS

LED DISPLAY—Shows status of system and water quality.

STATUS LED—Shows operating status of unit.

WATER QUALITY LED—Green if OK, Red if above limit.

POWER KEY—Places controller in operating or standby mode.

SP—Setpoint adjustment screw.

If technical assistance is required,
contact HydroLogic directly:
Toll-free 888-426-5644

SYSTEM OPERATION

GENERAL OPERATION

The unit has 2 modes of operation, a standby mode and an operating mode. In the standby mode, the unit is effectively off. All outputs are turned off and the display shows OFF. In the operating mode, the unit operates automatically. All inputs are monitored, and the outputs are controlled accordingly. Pressing the power key will toggle the unit from standby to operate or from operate to standby. If power is removed from the unit, when power is reapplied, the unit will restart in the mode it was in when power was removed.

DISPLAY AND STATUS INDICATORS

The display is a 3-digit display. System operating status, the TDS reading and the TDS setpoint are shown on this display. A red/green LED indicates the system status in conjunction with the display. Refer to Table 1 for the description of the operation of the display and LED.

CONDITION	DISPLAY	STATUS LED
RO OFF	OFF	
RO START DELAY	---	
RO OPERATING		STEADY GREEN
TANK FULL	FUL	
TANK FULL RESTART	FUL	SLOW FLASH GREEN
PRETREAT LOCKOUT	PL	
FLUSH	FLS	
PRESSURE FAULT	PF	FLASHING RED
PF AUTO RESET	PF	
PF AUTO RETRY	PF	STEADY RED

Table 1

RO START DELAY (---)

When the controller is placed in the operating mode or restarts from a shutdown condition, the inlet valve will open, and a 5 second time delay will start. During the delay, --- will show on the water quality display. After this delay, the RO pump will start. The water quality display will now show the current water quality. The status lamp will show steady green.

PRESSURE FAULT (PF)

If the pressure fault input is active for 2 seconds, a pressure fault condition will occur. This will cause the controller to shut down. "PF" will show on the water quality display and the status lamp will flash red. To clear the pressure fault, press the power key twice.

SYSTEM OPERATION (CONTINUED)

PRESSURE FAULT (PF) RETRY

When a pressure fault occurs, the controller will shut down for 30 seconds and then attempt to restart. If the pressure fault is still active, the controller will shut down for 5 minutes and then attempt to restart. If the pressure fault is still active, the controller will shut down for 30 minutes and attempt to restart. If the pressure fault is still active, the controller will lockout for the pressure fault. During the retry delays, the water quality display will show PF and the status lamp will be a steady red. If during one of the retries, the controller can start and run continuously for 10 seconds, the retry function is reset. If a pressure fault occurs, the PF retry cycle will repeat from the beginning. If a pressure fault condition occurs, the PF retry function will operate as described above. The PF retry function will continue in a 30 second, 5-minute, 30 minute and 60-minute cycle until the pressure fault condition clears.

TANK FULL (FUL)

If the tank full input is active for 5 seconds, the controller will shut down for a tank full condition. The water quality display will show FUL. When the tank full condition clears, the unit will restart after the selected restart delay. During the restart time, the status lamp will flash green.

PRE-TREAT LOCKOUT (PL)

If the pre-treat lockout input is active for 2 seconds, the controller will shut down for a pre-treat lockout condition. The water quality display will show PL. When the pre-treat lockout condition clears, the unit will restart.

WATER QUALITY DISPLAY

The water quality display shows the current water quality when the controller is operating normally and status messages when the controller is shut down. The water quality display is 0–999 PPM. If the water quality is above 999, the display will show ^ ^ ^. If the water quality is below the setpoint, the water quality lamp will be green. If the water quality is above the setpoint (500 PPM), the water quality lamp will be red.

MEMBRANE FLUSH

When a flush is initiated, the flush valve will operate, and the flush will last 5 minutes. The flush can occur when a tank full condition occurs. **DO NOT UNPLUG DURING FLUSH.**

SYSTEM ACCESSORY



Filter Removal Tool **HL 24025**

- 1/2 " MNPT

SYSTEM WARRANTY

ONE-YEAR LIMITED WARRANTY

WARRANTY TERMS

Subject to the terms and conditions set forth hereinafter, manufacturer (hereafter “Manufacturer”) warrants to the original purchaser (hereafter the “Customer”) that the systems and products manufactured by the Manufacturer are free from defects in material and in workmanship for twelve (12) months from the Warranty Commencement Date (as defined below) only when used strictly in accordance with the applicable operating instructions and within the range of the operating conditions specified by the Manufacturer for each such product.

In order to maintain the Manufacturer’s Warranty, an operating log must be maintained, and copies will need to be sent to your local dealer or distributor for review. This Warranty does not extend to systems, equipment, or components manufactured by others, nor to systems, equipment, or components manufactured by others and distributed by the Manufacturer. This Warranty does not extend to equipment or components manufactured by others which have been incorporated into a product by the Manufacturer but, if allowable, the Manufacturer hereby assigns, without Warranty, to the Customer its interest, if any, under any Warranty made by the Manufacturer of such equipment or component. This Warranty does not cover disposable items such as fuses, O-rings, regeneration materials/chemicals, or other such disposable items, which must be replaced periodically under the normal and foreseeable operating conditions of the goods warranted hereby.

WARRANTY COMMENCEMENT DATE

The Warranty Commencement Date for each product by the Manufacturer shall be the later of the date of: (1) receipt by the Customer, or (2) the date of installation at the Customer’s premises provided that such installation must occur within three (3) months of shipment from the Manufacturer’s manufacturing facility. In no event shall the Warranty Commencement Date exceed three (3) months from the shipment from Manufacturer’s facility. The Customer shall provide proof of purchase in order to exercise rights granted under this Warranty. If requested by the Manufacturer, the Customer must also provide proof of the installation date. Proof of installation shall be returned by Customer to the Manufacturer within thirty (30) days after installation by virtue of supplying a Warranty Validation Card supplied with each Manufacturer product fully completed and signed in ink by the Customer and the authorized installer of the product.

WARRANTY SERVICE

MANUFACTURER’S OBLIGATION UNDER THIS WARRANTY IS LIMITED TO THE REPAIR OR REPLACEMENT (AT MANUFACTURER’S SOLE DISCRETION) OF ANY PRODUCT, OR COMPONENT THEREOF, PROVED TO BE DEFECTIVE IN MATERIAL OR WORKMANSHIP WITHIN THE COVERED WARRANTY PERIOD.

The Customer, at the Customer’s risk and expense, shall be responsible for returning such product or component, only after obtaining a Return Goods Authorization (RGA) number from the Manufacturer, arranging for freight prepaid, and in conformance with any special packaging and shipping instructions set forth on the operation documentation or RGA instructions, or as otherwise reasonably required, to Manufacturer’s address, together with (1) RGA number issued by the Manufacturer at Customer’s request; (2) proof of purchase and, if necessary, proof of

SYSTEM WARRANTY (CONTINUED) **ONE-YEAR LIMITED WARRANTY**

installation date; (3) a Return Goods Authorization Form; (4) a description of the suspected defects; (5) the serial number of the Manufacturer product alleged to be defective; and (6) a description of the type of water and pretreatment equipment which has been utilized in connection with the product, if any; (7) an operating log, which can be found in the product manual. Manufacturer shall, in Manufacturer's reasonable discretion, be the sole judge of whether a returned product or component is defective in material or workmanship.

Required or replaced products or components shall be returned surface freight. In genuine emergency situations, Manufacturer will at Manufacturer's sole discretion forward replacement parts to Customer without waiting for authorized return of the questionable part(s). In such cases, Customer will issue a purchase order or other payment guarantee prior to shipment. If the returned part is found to have been misused or abused, or the defective part is not received by Manufacturer within thirty (30) days; the Customer will be invoiced for the replacement part(s) provided. This Warranty does not cover or include labor and/or travel to the Customer's premise or location or any other location. Charges of \$1000 per day plus associated travel expenses will be incurred by the Customer in providing the Warranty Service at any location other than Manufacturer's main headquarters; that is if the Manufacturer deems that the product is not covered by said Warranty. The Manufacturer reserves the right to precondition such travel to Customer's premises upon prepayment of Manufacturer's anticipated costs of attending such premises.

VOIDABILITY OF WARRANTY

This Warranty shall be void and unenforceable as to any Manufacturer product which has been damaged by accident, mishandling, abuse or has been repaired, modified, altered, disassembled or otherwise tampered with by anyone other than Manufacturer or an authorized Manufacturer service representative; or, if any replacement parts are not authorized by Manufacturer have been used, or, the product has not been installed, operated and maintained in strict accordance and adherence with the operating documentation and manuals for such product. Any expressed Warranty, or similar representation of performance set forth in the operation documentation for media or resin incorporated into a product by the Manufacturer shall be void and unenforceable unless the feed water requirements set forth in the operating documentation for such product are unequivocally and strictly adhered to.

HYDROID™

BY **HydroLogic**®
PURIFICATION SYSTEMS

370 Encinal Street
Suite 150
Santa Cruz, CA
95060

ph: 888.426.5644
fax: 831.336.9840

techsupport@hydrologicsystems.com
hydrologicsystems.com



BUILT IN U.S.A.