INSTRUCTIONS

ACTIVE AIR[®]

75 PT COMMERCIAL HUMIDIFIER



AAHC75P

SPECIFICATIONS

ACTIVE AIR COMMERCIAL HUMIDIFIER, 75 PT – AAHC75P

Dimensions	12" x 12" x 16"	Coverage	160–320 sq/ft
Input Power	110–120V, 60Hz	Water Input Size	¼"
Operating Power	90 Watts (0.8 Amps)	Tank Size	3 Liters
Cord Length	6 ft	Noise	62 dba
Max Output	75 pints/day		

Parts List

- 15 Motor (110V/60HZ)
- 16 Capacitor (250V/60HZ)
- 17 Fan Blade
- 18 Motor Cover
- 19 Motor Support
- 20 Cord
- 21 Atomizing Screen
- 22 Hub Assembly
- 23 Disk
- 24 Pump
- 25 Fogging Head
- 26 Screen
- 27 Housing
- 28 Mid Pan
- 29 Lower Pan
- 30 Strainer Support
- 31 Strainer Screen
- 32 Leg
- 33 Float Valve
- 34 Reservoir Pan
- 35 Spring
- 36 Handle

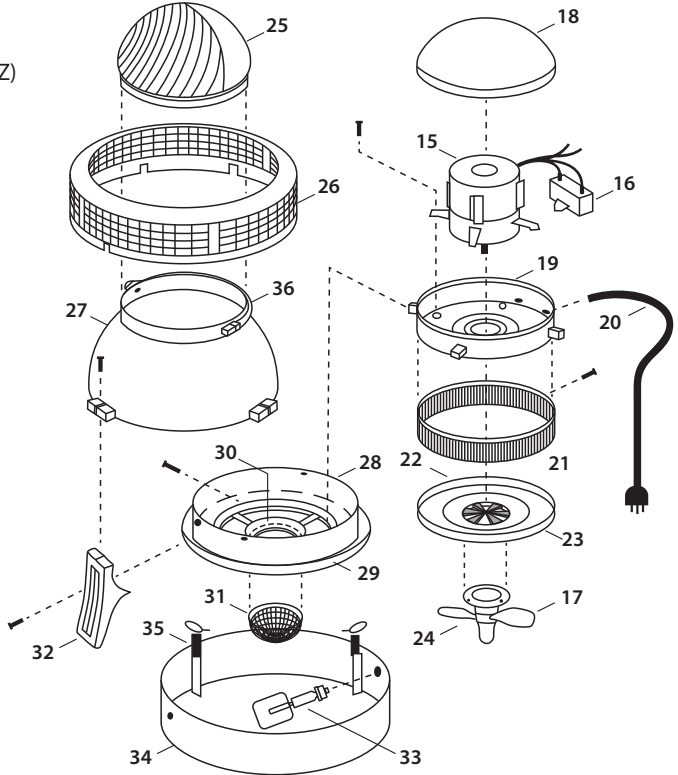

INSTRUCTIONS

CAUTION

- If the supply cord is damaged, it must be replaced by the manufacturer, its service agent, or similarly qualified person in order to avoid a hazard.
- Unplug the appliance before filling or cleaning.
- Maximum water pressure: 73 PSI (.5 mpa).

WATER CONNECTION

Place the unit on a level surface, such as a benchtop or floor.

If your environment has little to no ventilation, place the unit in a central location. In a ventilated area, place unit near the intake end. When the unit is in the desired location, connect a water supply to the female 6mm inlet. Options:

- Plumb directly to a water supply (6mm plastic tubing is preferred).
- Connect to a garden hose fitting.
- Plumb to a storage tank higher than the fogging unit (gravity feed).

POWER CONNECTION

Plug the unit directly into an electrical outlet and listen for a smooth, quiet operation. Motor shaft should be centered and vertical. Make any necessary adjustments. After evaluation, connect the unit to desired control device:

- Plug into a sensor for best automatic control.
- Plug into a timer for specific automatic control intervals.
- Plug directly to an electrical supply for manual operation.

OPERATION

 ***WARNING: Designed for atomizing water only! Do not use flammable, toxic or corrosive liquids.**

- Use the fogging head for directional fogging output and a drier fog.
- For maximum fogging and circulation, remove lower housing, upper housing, and fogging head. Fog will propel 4–5 feet above the unit.

TROUBLESHOOTING

NO FOG: Check for motor rotation. If motor is operating properly, check for an adequate amount of water in the pan (¼" to 1¼"). If the pan runs dry, the float valve may be sticking in the Up position. If so, the inlet water pressure needs to be reduced. If water supply is adequate, check the tapered pump for internal calcium build-up. Remove, inspect, and clean as needed.

OVERFLOWING PAN: An overfilled pan can cause poor quality fog and wetness around the unit. A leaky float valve or a float that has filled with water may be the problem.

To check the float, raise it out of the water and visually inspect it. No water should be inside and it should not sink. If OK, then check for leaky valve. Turn water off and remove the fogger from the pan. Empty the pan and towel dry. Hold the float in the Up position and turn on the water. If any water enters the pan while the float is in the Up position, the float valve needs to be replaced.

MAINTENANCE

Regularly clean the reservoir pan assembly with soap and water to remove dirt and sediment. If algae is present, sterilize affected parts with liquid bleach after cleaning.

Periodically remove strainer screen and thoroughly flush. Check to make sure the tapered pump/fan blade assembly is free of debris.

Once every three months, check unit for calcium buildup. If buildup deposits are present, disconnect the water and take the unit outside. Pour calcium-dissolving solvent (available in local hardware stores) in pan and operate unit outside to soften and remove the deposits.

About once a year, remove the housing to check the SST atomizing screen to be sure the slots are clear of mineral buildup. To clean, scrub with a calcium-dissolving solvent.

WARRANTY



LIMITED WARRANTY

Hydrofarm warrants the **AAHC75P** to be free from defects in materials and workmanship. The warranty term is for one year prorated beginning on the date of purchase. Misuse, abuse, or failure to follow instructions is not covered under this warranty. Hydrofarm will, at our discretion, repair or replace the **AAHC75P** covered under this warranty if it is returned to the original place of purchase. To request warranty service, please return the **AAHC75P**, with original sales receipt and original packaging, to your place of purchase. The purchase date is based on your original sales receipt.

AAHC75P_Instructions_Dec2018-rev.December4,20189:40AM