

90-2393

SAFETY INSTRUCTIONS

⚠ WARNING

1. 208-240 volts may cause serious injury from electric shock. Disconnect electrical power before starting installation or servicing. Leave power disconnected until installation/service is completed.
2. Sharp edges may cause serious injury from cuts. Use care when cutting plenum openings and handling duct work.
3. Dropping may cause personal injury or equipment damage. Handle with care and follow installation instructions.

⚠ CAUTION

1. Read all instructions before beginning installation.
2. This appliance is not intended for use by persons (including children) with reduced physical, sensory or mental capabilities, or lack of experience and knowledge, unless they have been given supervision or instruction concerning use of the appliance by a person responsible for their safety. Children should be supervised to ensure that they do not play with the appliance.
3. Do not use in pool applications. Pool chemicals can damage the dehumidifier.
4. Do not use solvents or cleaners on or near the circuit board. Chemicals can damage circuit board components.
5. Wait 24 hours before running the unit if it was not shipped or stored in the upright position
6. If the supply cord is damaged, it must be replaced by the manufacturer, its service agent or similarly qualified persons in order to avoid a hazard.

READ AND SAVE THESE INSTRUCTIONS

TABLE OF CONTENTS

SAFETY INSTRUCTIONS	1
SPECIFICATIONS	3
UNPACKING THE DEHUMIDIFIER	4
LOCATION CONSIDERATIONS	4
FLOOR MOUNTING	4
SUSPENDING THE DEHUMIDIFIER	5
Install Brackets for Suspending Unit	5
Hanging the Dehumidifier	5
Ducting	5
DRAIN INSTALLATION	6
Leveling	6
Condensate Pan, Condensate Pump and Float Switch	6
HARD WIRING – LINE VOLTAGE	7
MODEL A77 – REMOTE CONTROL AND WIRING	8
Alternate External Controls	8
SYSTEM SET UP & CHECKOUT	9
Installer Test Mode	10
START UP AND SEQUENCE OF OPERATION	11
Using the Dehumidifier Control	11
Using Model A77 Control	11
TROUBLESHOOTING	12
Table 1 – Diagnostic Codes	12
Table 2 – Troubleshooting Guide	13
SERVICE PARTS	14
LIMITED WARRANTY	15

SPECIFICATIONS

ENVIRONMENTAL

Operating Temperature Range: 60°F – 85°F

Operating Dew Point: 40°F – 75°F

MECHANICAL

Weight: 118 lbs (without packaging)

Drain Size: 3/4" FNPT

Capacity: 210 PPD @ 80°F, 60% RH

Filter: MERV 11

Airflow: 525 CFM (free flow)

ELECTRICAL

Voltage: 208-240 VAC ~, 1ø, 60 HZ

Operating Current: 7.2A @ 80°F, 60% RH

Efficiency: 3.0 L/kW-hr (6.3 pints/kW-hr)
@ 80°F, 60% RH

DIMENSIONS

FIGURE 1 – DIMENSIONS (INCHES)

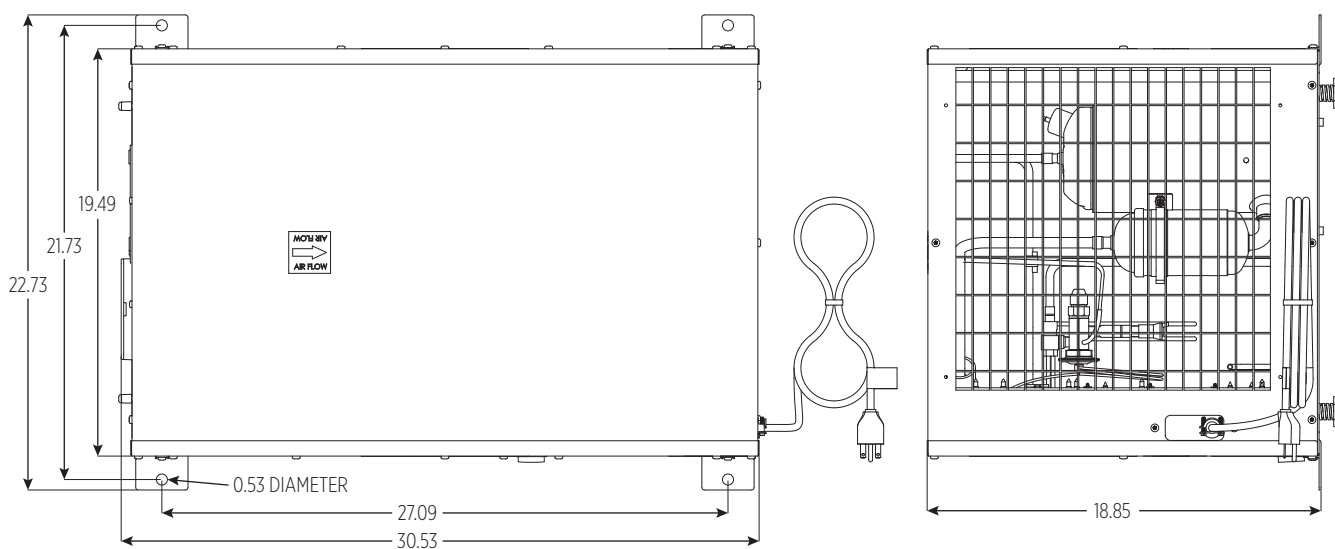

90-2394

UNPACKING THE DEHUMIDIFIER

Remove the unit from the carton. Cut the retaining band that secures the compressor to the shipping bracket and remove the band and the bracket. See **FIGURE 2**.

INCLUDED IN THE CARTON

- Dehumidifier
- Installation manual
- Hanging brackets
- Model A77 control
- 3/4" MNPT x 3/4" hose barb fitting
- 10 feet of 3/4" clear PVC flexible drain hose
- Terminal screwdriver
- 30 feet of thermostat cable
- MERV 11 filter

FIGURE 2 – REMOVE SHIPPING BRACKET

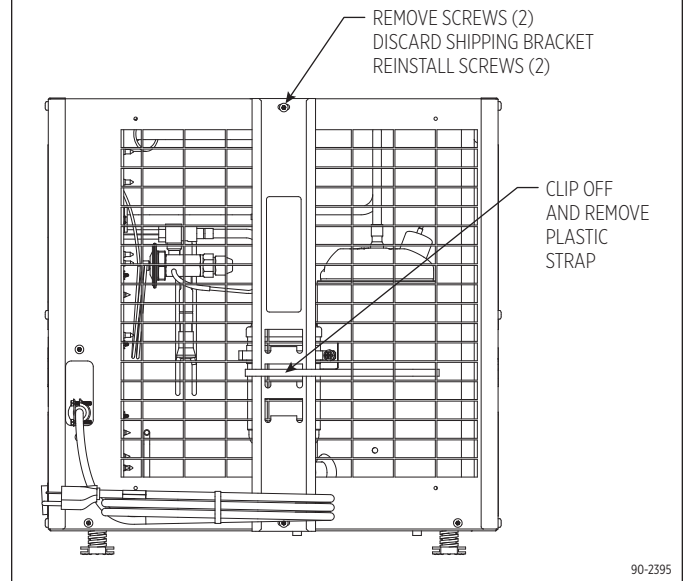

LOCATION CONSIDERATIONS

This appliance is classified as to not be accessible to the general public. The dehumidifiers should be spaced evenly throughout the area to be dehumidified with the following recommendations:

1. Avoid placement where the discharge of one dehumidifier is pointing toward the inlet of another.
2. Avoid locating the dehumidifier inlet too near a supply register. Space is not usually available to totally avoid this, but minimizing the amount of cold air that is discharged to the dehumidifier inlet will improve moisture removal performance of the dehumidifier.
3. Account for handling dehumidifier condensate by considering drain or sump pump locations.
4. Leave appropriate room on the drain side of the dehumidifier for wiring and service.
5. Allow sufficient space near the inlet (6" minimum) to be able to remove/install a filter. More space ensures no loss of airflow due to restriction at the inlet.

FIGURE 3 – SPACE CLEARANCES

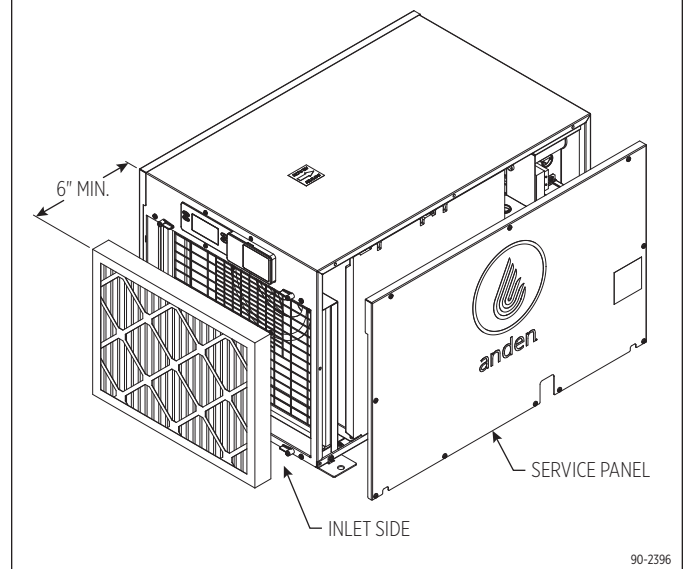

FLOOR MOUNTING

The drain hose must continuously slope downward toward the drain. Use solid supports as needed to elevate the unit enough to allow for continuous drain slope. Use the adjustable feet to level the unit right to left and front to back so that unit drains properly.

SUSPENDING THE DEHUMIDIFIER

INSTALL BRACKETS FOR SUSPENDING UNIT

The brackets are designed to accommodate up to 1/2" threaded rod.

1. Insert bracket into slots on the bottom of the base. See **FIGURE 4**.
2. Rotate the bracket up toward the dehumidifier and secure the bracket to the side of the dehumidifier using #10 sheet metal screws (provided). See **FIGURE 5**.
3. Repeat for remaining three brackets.

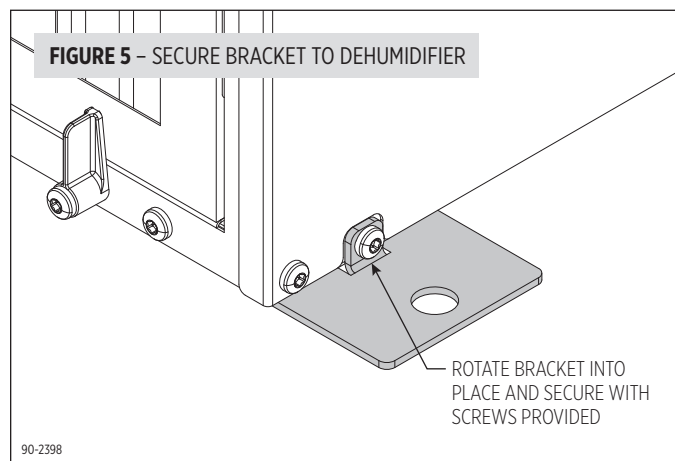
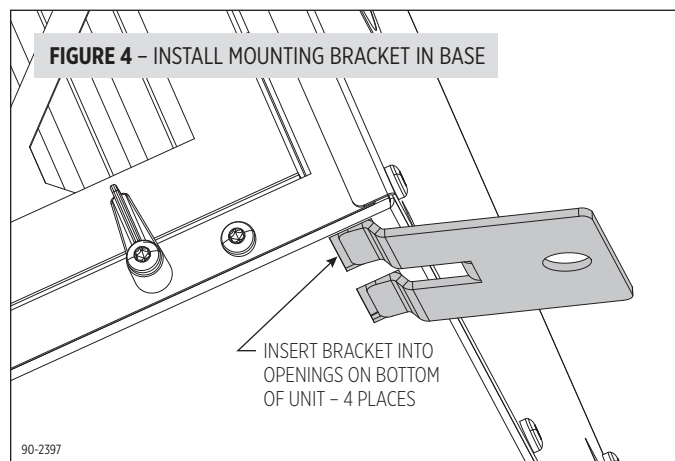

HANGING THE DEHUMIDIFIER

Use the threaded rod to suspend the unit from appropriate ceiling structure. The unit weight is 118 lbs. Install vibration isolators if located in an area where noise could be a concern. Level unit right to left and front to back so that unit drains properly.

DUCTING

Use duct kit part number 5790 for installing ductwork to the dehumidifier. Maximum recommended external static pressure is 0.2" w.c.

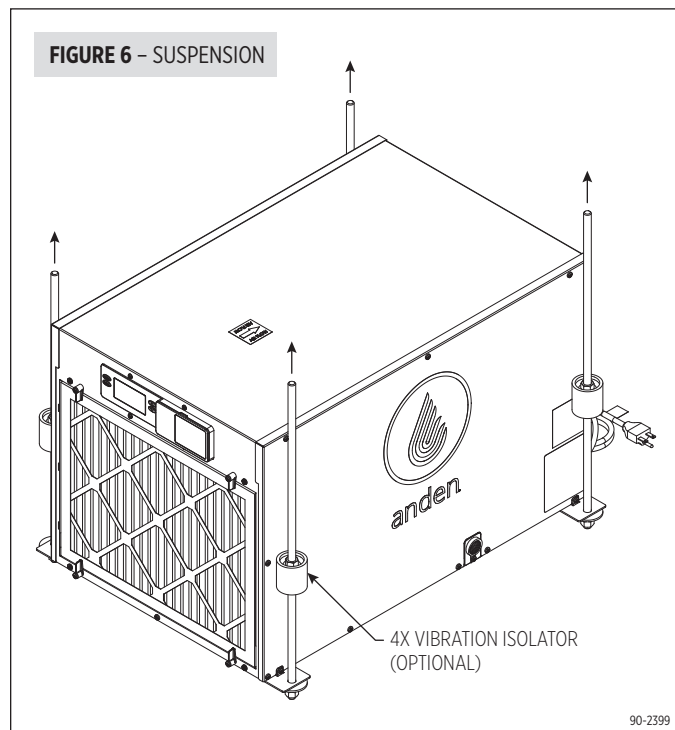

DRAIN INSTALLATION

The drain outlet on the dehumidifier can be hard piped using a 3/4" PVC Slip x 3/4" MNPT fitting and 3/4" nominal drain tubing or the provided 3/4" MNPT x 3/4" hose barb fitting and 3/4" clear PVC tubing can be used to drain the dehumidifier. Always maintain a constant downward slope from the dehumidifier to the drain and do not allow soft tubing to curl up which may result in air lock. **NOTE:** PTFE thread seal tape is recommended for the threaded connection and **hand tighten only**. If hard pipe is used, PVC primer and cement is recommended for the slip fit connection. Test all joints to ensure they are leak free before completing the installation.

LEVELING

The feet can be adjusted to level the unit, and if required, to accommodate drain fittings and a secondary condensate pan. **Leveling is required** to ensure proper drainage from the dehumidifier. See **FIGURE 7**.

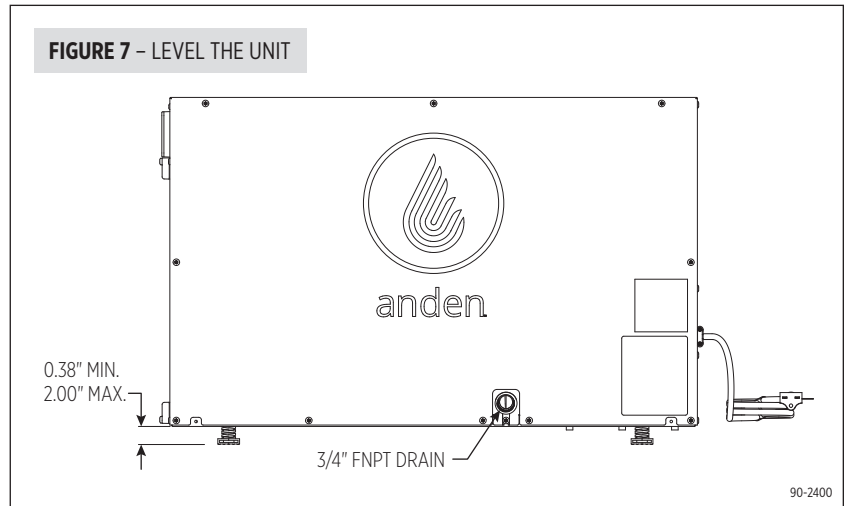

CONDENSATE PAN, CONDENSATE PUMP AND FLOAT SWITCH

A condensate pan is recommended when suspending the dehumidifier over finished areas or product. Adhere to local codes regarding draining of the condensate pan. If a condensate pump is needed, install it in the condensate pan as well.

Install a condensate overflow safety switch (i.e. float switch) in the condensate pan, remove the factory installed jumper wire between the Float Switch terminals on the control and wire the float switch to the dehumidifier as shown in **FIGURE 8**. Overflow safety switches on condensate pumps can be wired to the Float Switch terminals in a similar fashion.

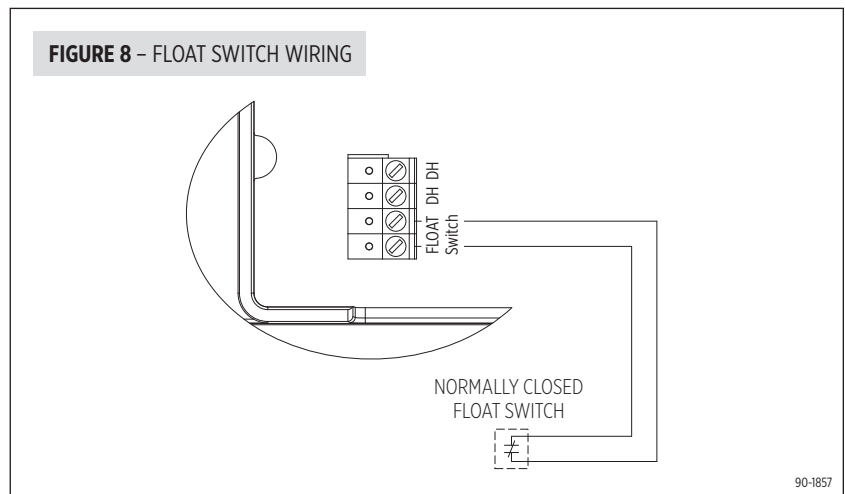

HARD WIRING – LINE VOLTAGE

⚠ CAUTION

If the supply cord is damaged, it must be replaced by the manufacturer, its service agent or similarly qualified persons in order to avoid a hazard.

The dehumidifier comes with a power cord that has a NEMA 6-15P plug that can simply be plugged into a corresponding NEMA 6-15R receptacle. The plug can be removed and replaced by hard-wired electrical service if desired.

United States Installation: Make all electrical connections in accordance with the current edition of the NEC ANSI/NFPA 70 and any local codes or ordinances that may apply.

Canada Installation: Make all electrical connections in accordance with the current edition of the Canadian Electrical Code CSA C22.1 and any local codes or ordinances that may apply.

Voltage	208-240 VAC ~, single phase, 60 Hz
Minimum Circuit Ampacity	11A
Maximum Fuse or Circuit Breaker Size	20A

1. Disconnect electrical service at the main fuse or circuit breaker.
2. Run electrical service to where the dehumidifier is to be installed following all required local and national codes and standards.
3. Remove the side panel from the dehumidifier.
4. Loosen the terminal screws securing the power cord wires to the terminal blocks and ground lug.
5. Use channellock pliers to remove the strain relief and power cord from the unit. Pinch the side of the strain relief to release it from the opening in the sheet metal and pull it away from the dehumidifier.
6. Route the service wires through the opening in the dehumidifier and secure the cable or conduit to the opening in the dehumidifier using fittings/clamps intended for the conduit/cable used.
7. Insert the black service wire into the L1 terminal and the white service wire into the L2 terminal. Secure the wires into the terminals by tightening the terminal screws.
8. Insert the ground wire (bare or green) of the electrical service into the ground lug and secure it in place by tightening the ground lug screw.
9. Reattach the side panel to the dehumidifier.
10. Restore electrical service at the fuse or circuit breaker.

FIGURE 9 – HARD WIRING TO REPLACE THE POWER CORD

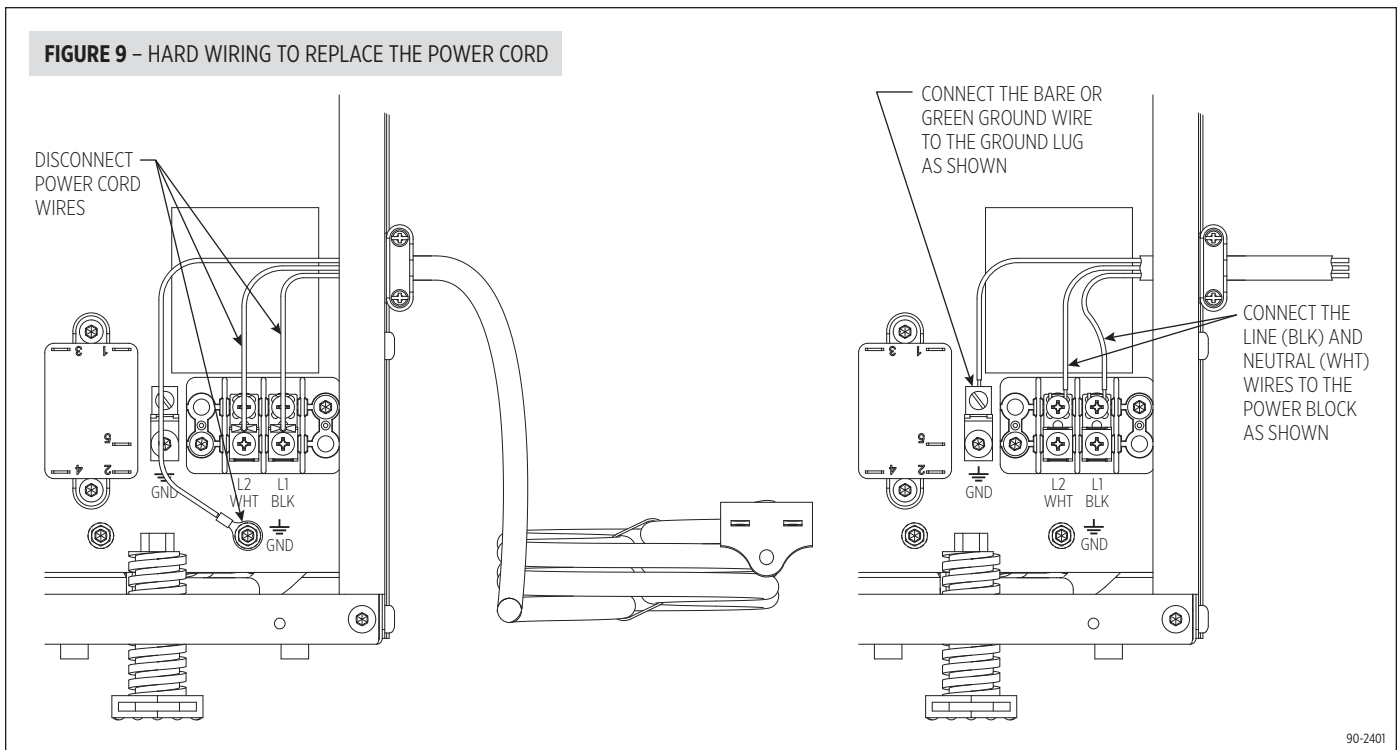

90-2401

MODEL A77 – REMOTE CONTROL AND WIRING

NOTE: Use 18-22 AWG wire for control wiring.

Humidity can be controlled using the internal dehumidifier control, a Model A77 control or a different external control like a thermostat.

Without an external control, the dehumidifier will turn on its blower for three minutes every 15, 30 or 45 minutes depending on how often the unit is set to sample the air. The dehumidifier can also be set to sample the air continuously (see **AIR SAMPLING** on page 10). The blower is turned on to get a representative reading of the room relative humidity. A shorter sampling period reduces the duration of any humidity spikes that might occur when neither the air conditioning nor the dehumidifier are running. To reduce energy consumption the sampling time can be set to a longer period.

Installing an external control eliminates the need to run the dehumidifier blower for sampling as the control is constantly measuring the humidity close to the canopy. When the humidity level rises above the setting, the dehumidifier is turned on.

To install the Model A77 control:

1. Unplug the dehumidifier or turn off power to the circuit at the breaker or fuse.
2. Run a 4-wire thermostat cable (use 18–22 AWG wire) from the Model A77 to the control of the dehumidifier.
3. Trim about 1/4" of insulation from the end of the wires on each end. Insert the wire into the terminals as shown in **FIGURE 10** and tighten to secure.
4. Restore dehumidifier power. There is a delay of three minutes after restoring power before the dehumidifier will respond to the control.
5. Go to **REMOTE CONTROL** on page 9 to configure the dehumidifier control to respond to the Model A77.

The Model A77 will measure the relative humidity and turn the dehumidifier on and off to control the humidity level to the desired setting. The humidity setting can be adjusted from the control while the display allows easy access and monitoring of the humidity level in the space. It is recommended that the Model A77 be mounted at/near canopy height. Shield the Model A77 from direct exposure to HPS or LPS lighting.

Press the ON button on the Model A77 to turn on the control. The UP/DOWN arrow buttons are used to set the desired humidity setting. At all other times, the Model A77 will display the measured humidity level. Reference the Model A77 Installation and Operating Instructions for set-up.

ALTERNATE EXTERNAL CONTROLS

An 8800 Series thermostat can be used to control the HVAC equipment, and for dehumidifier control in place of the Model A77. The 8800 Series thermostat has Wi-Fi capability so the conditions in the room can be monitored at any time from any location. Additionally, up to four remote sensors can be mounted near the canopy and connected to a single thermostat. The four humidity measurements can be averaged and the thermostat will turn on the dehumidifier based on the averaged value.

Reference the thermostat Installation Instructions and Owner's Manual for wiring, set-up and operating details.

FIGURE 10 – MODEL A77 REMOTE CONTROL WIRING

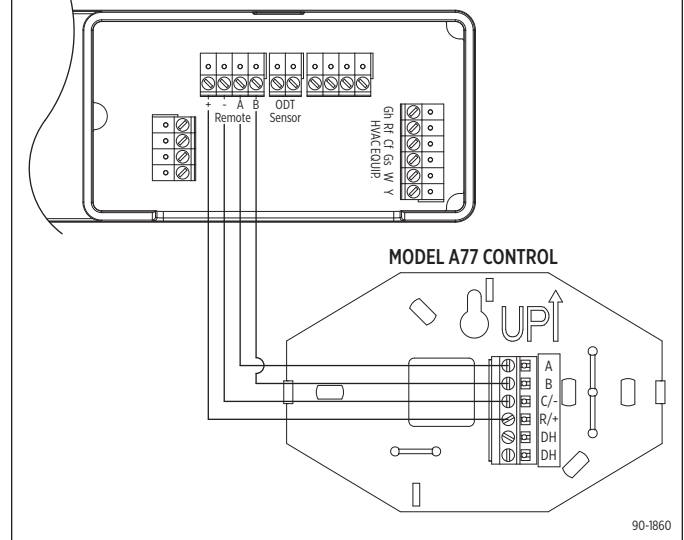

SYSTEM SET-UP & CHECKOUT

Skip set up and proceed to **INSTALLER TEST MODE** on page 10 unless:

- A Model A77 or other external control is to be installed
- changing the air sampling rate

1. Check all wiring.
2. Make sure the wire access cover has been snapped back onto the on-board control.
3. Plug unit in and turn power switch to ON.
4. The on-board control screen should display OFF.

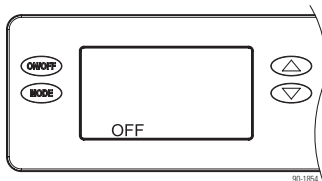

NOTE: If the display backlight is not on, the first button press (any button) will only turn on the backlight. Press the button a second time to achieve function.

5. Hold the MODE button on the on-board control for 3 seconds to enter the Installer Set-up Menu.
6. Navigate through the following screens to set up the dehumidifier for the installed application.

Use the UP or DOWN arrows to select items and use MODE to switch to the next set-up option. To exit installer set-up, all options must be scrolled through using the MODE button.

7. After the installer set up options have been completed, DONE will blink for 3 seconds and the control will return to the OFF screen.

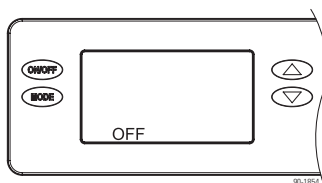
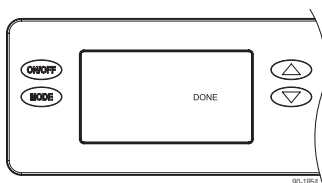

REMOTE CONTROL

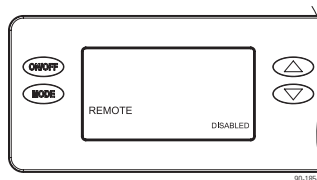

If not installing a Model A77, leave DISABLED and press MODE to go to the next screen.

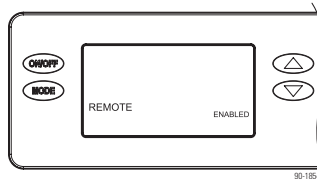

If installing a Model A77, press the UP or DOWN button to change to ENABLED and then press MODE to go to the next screen

EXTERNAL CONTROL

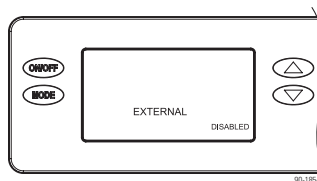

If using the dehumidifier on-board control, leave DISABLED and press MODE to go to the next screen.

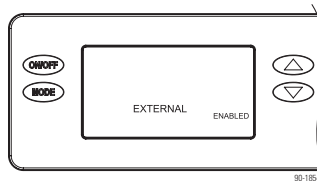

If using an 8800 Series thermostat as an external control, use the UP or DOWN button to select ENABLED, then press MODE to go to the next screen.

AIR SAMPLING

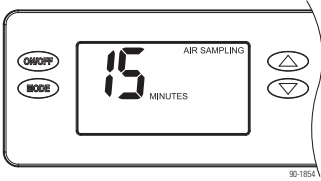

Use the UP or DOWN button to adjust how frequently the dehumidifier samples the air to determine whether or not to dehumidify. Fewer minutes means the dehumidifier will sample more

frequently to minimize humidity swings, but increases cost to operate due to more frequent fan operation. Press MODE when done to move to the next screen.

RH OFFSET

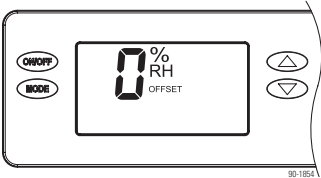

An offset can be applied to the on-board humidity reading to avoid discrepancies with other humidity measuring devices in the home. Use the UP/DOWN arrows to select an offset from -5% to 5%. Press MODE to exit the installer set-up screens.

INSTALLER TEST MODE

If everything is properly wired, the dehumidifier and all of the wired components will turn on and off during Installer Test Mode to demonstrate that all are properly operating. Installer Test Mode lasts for four (4) minutes. If the ON/OFF button is pressed during test mode, the dehumidifier will exit Installer Test Mode and return to the OFF screen.

DEHUMIDIFICATION ONLY

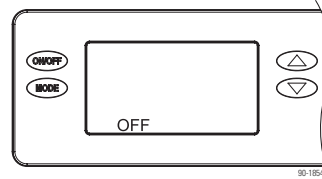

If the dehumidifier is not already OFF, press the ON/OFF button to turn it off.

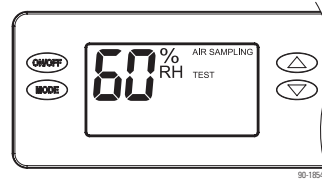

Press and hold the ON/OFF button and MODE buttons for 3 seconds. The measured humidity, AIR SAMPLING and TEST will show on the display.

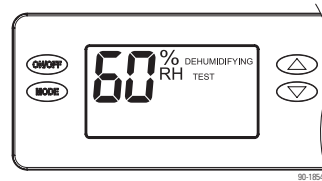

After three (3) minutes the dehumidifier compressor will turn on and DEHUMIDIFYING will replace AIR SAMPLING on the control screen.

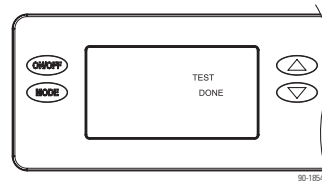

After one minute of compressor operation, all outputs will turn off and DONE will blink for 3 seconds and then return to the OFF screen.

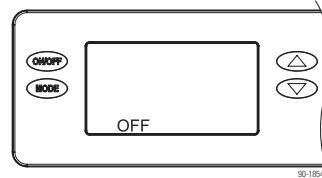

START UP AND SEQUENCE OF OPERATION

USING THE DEHUMIDIFIER CONTROL

1. Press the ON/OFF button to turn the dehumidifier control ON. The display will show the current setting, and the dehumidifier blower will turn on to start sampling the air.
The setting will be replaced by the measured humidity and "AIR SAMPLING" will show on the display.
2. Use the UP or DOWN button to adjust the humidity setting as desired.
3. After three (3) minutes of sampling, the measured humidity will be compared to the setting:
 - a. If the humidity is above the setting, the dehumidifier compressor turns on and "AIR SAMPLING" will be replaced by "DEHUMIDIFYING". The compressor remains on until the measured humidity falls 3% RH below the setting.
 - b. If the measured humidity is below the setting, the blowers turn off and the display returns to showing the RH setting.
4. The dehumidifier will sample again after the number of minutes selected during the Air Sampling portion of the System Set Up (see page 10), or any time the humidity setting is lowered.

USING THE MODEL A77 CONTROL

1. Press the ON/OFF button to turn the dehumidifier control ON. "REMOTE" will show on the display to indicate that an external control is wired to the dehumidifier.
2. At the Model A77, press the ON button; the Model A77 will display the measured RH.
3. Use the UP or DOWN button on the Model A77 to adjust the humidity setting as desired.
4. If the RH measured by the Model A77 rises above the setting, the dehumidifier will turn on. "DEHUMIDIFYING" will appear on the dehumidifier control display to show that the Model A77 is calling for dehumidification. The dehumidifier will turn off when the RH measured by the Model A77 drops 3% RH below the setting.

TROUBLESHOOTING

Technical Support is available Monday through Friday, 7:00 a.m. to 5:00 p.m. CST, at (800) 972-3710. Use the guides on the following pages to identify and correct system faults. Contact Technical Support before replacing the unit or any components and for additional troubleshooting.

DIAGNOSTIC CODES

When an error occurs, the Diagnostic Code along with SERVICE REQUIRED will be displayed on the control screen. If a 5818 Alert Light is used, the light will turn on when an error occurs.

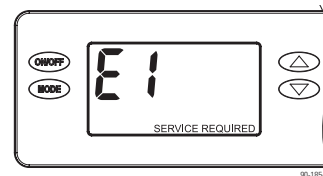

TABLE 1 – DIAGNOSTIC CODES

Diagnostic Code	Failure Mode	Action	Reset
E1	Internal Humidity or Temperature Sensor Open or Shorted	<ol style="list-style-type: none"> 1. If connection okay, replace User Interface, Part No. 5738. 	Cycle Power
E3	Model A77 Remote Control Communication Loss	<ol style="list-style-type: none"> 1. Check connections between Model A77 and dehumidifier control board. Terminals should be fully inserted and secured in the control board and Model A77 control terminals. 2. If connections are correct and secure, turn off the dehumidifier and remove the Model A77. Use a short section of 4-wire cable to reconnect the Model A77 to the control board. Turn the dehumidifier back on and increase the dryness level setting on the Model A77. If the dehumidifier turns on, the problem is with the wiring between the dehumidifier and control. 3. If the dehumidifier does not turn on, call Technical Support. 	Self-Correcting
E4	Insufficient Capacity	<ol style="list-style-type: none"> 1. Check the frost sensor connection at the power board. Terminal should be fully seated on the power board pins. 2. Remove the side access panel and verify that the sensor is secured to the suction line. 3. If the sensor is connected and secured to the refrigeration line proceed to the next step. 4. Reset the fault by cycling power to the dehumidifier. 5. Turn the humidity setting down (below room/home humidity level) to make a dehumidification call. 6. Allow the fan and compressor to run for approximately 10-15 minutes and then enter diagnostic test mode by simultaneously pressing the UP ARROW and MODE buttons for 3 seconds. The LCD will display the temperature measured by the internal sensor while also displaying AIR SAMPLING and ON, the humidity measured by the internal sensor while also displaying %RH and ON, and the frost sensor temperature while also displaying ON. Scroll through these values and by using the UP/DOWN arrow buttons. 7. Record values and call Technical Support. 	Cycle Power
E5	High Temperature Thermistor Failure	<ol style="list-style-type: none"> 1. Check the high temperature sensor connection at the power board. Terminal should be fully seated on the power board pins. 2. Remove the side access panel and verify the sensor is not damaged and connected to the refrigeration line coming from the compressor. 3. If the sensor is connected and secured to the refrigeration line, it may need to be replaced with Part No. 5456 – contact Technical Support to confirm. 	Cycle Power
E6	Low Temperature Thermistor Failure	<ol style="list-style-type: none"> 1. Check the low temperature sensor connection at the power board. 2. Remove the side access panel and verify the sensor is not damaged and connected to the suction line. 3. If the sensor is connected and secured to the refrigeration line, it may need to be replaced with Part No. 5455 – contact Technical Support to confirm. 	Self-Correcting
E7	Float Switch Open	<ol style="list-style-type: none"> 1. Empty the condensate pan. 2. Check the float switch connection at the control board. 3. If not using a float switch, verify jumper is between float switch terminals on dehumidifier control board. 4. If the problem persists, replace the float switch. 	Self-Correcting
E8	Inlet Air Temperature Out of 50°F – 104°F range or dew point below 40°F	<ol style="list-style-type: none"> 1. Verify all ductwork is properly sealed. 2. If no signs of leak points, contact Technical Support. 	Self-Correcting

TABLE 2 – TROUBLESHOOTING GUIDE

Symptom	Possible Reason	Troubleshooting Procedure
Dehumidifier does not turn on/run.	No power to unit.	<ul style="list-style-type: none"> • Check that the dehumidifier is plugged in. • Check that the power switch is turned ON. • Check that the control is turned ON. • Check that the circuit breaker has not tripped.
Dehumidifier blower is running but with little or no airflow.	Pressure drop across dehumidifier is too high.	<ul style="list-style-type: none"> • Check dehumidifier air filter and replace if necessary. • Check for blocked duct work and clear.
Dehumidifier blower is running but compressor is not.	Float switch open.	<ul style="list-style-type: none"> • If float switch installed, check connections at control board and empty condensate pan. • If no float switch installed check that the jumper is installed at the float switch terminals on the control board.
	Coil frosting – defrost.	<ul style="list-style-type: none"> • Lack of or reduced airflow. Check dehumidifier air filter and replace if necessary. • Check for blocked duct work. • Inlet air conditions below 60°F. Increase the humidity setting.
	Inlet air temperature is outside of the 50°F – 104°F range or the dew point is below 40°F and there is a demand for dehumidification.	<ul style="list-style-type: none"> • Verify all ductwork is properly sealed.
Dehumidifier is not draining properly.	Drain line blocked or unit not level.	<ul style="list-style-type: none"> • Verify that the unit is level. • Check the drain line blockages and for a continuous downward slope.
Dehumidifier is producing hot air.	Normal function.	<ul style="list-style-type: none"> • Air is reheated across the condenser coil, resulting in a temperature rise between inlet and outlet, this is normal.

SERVICE PARTS

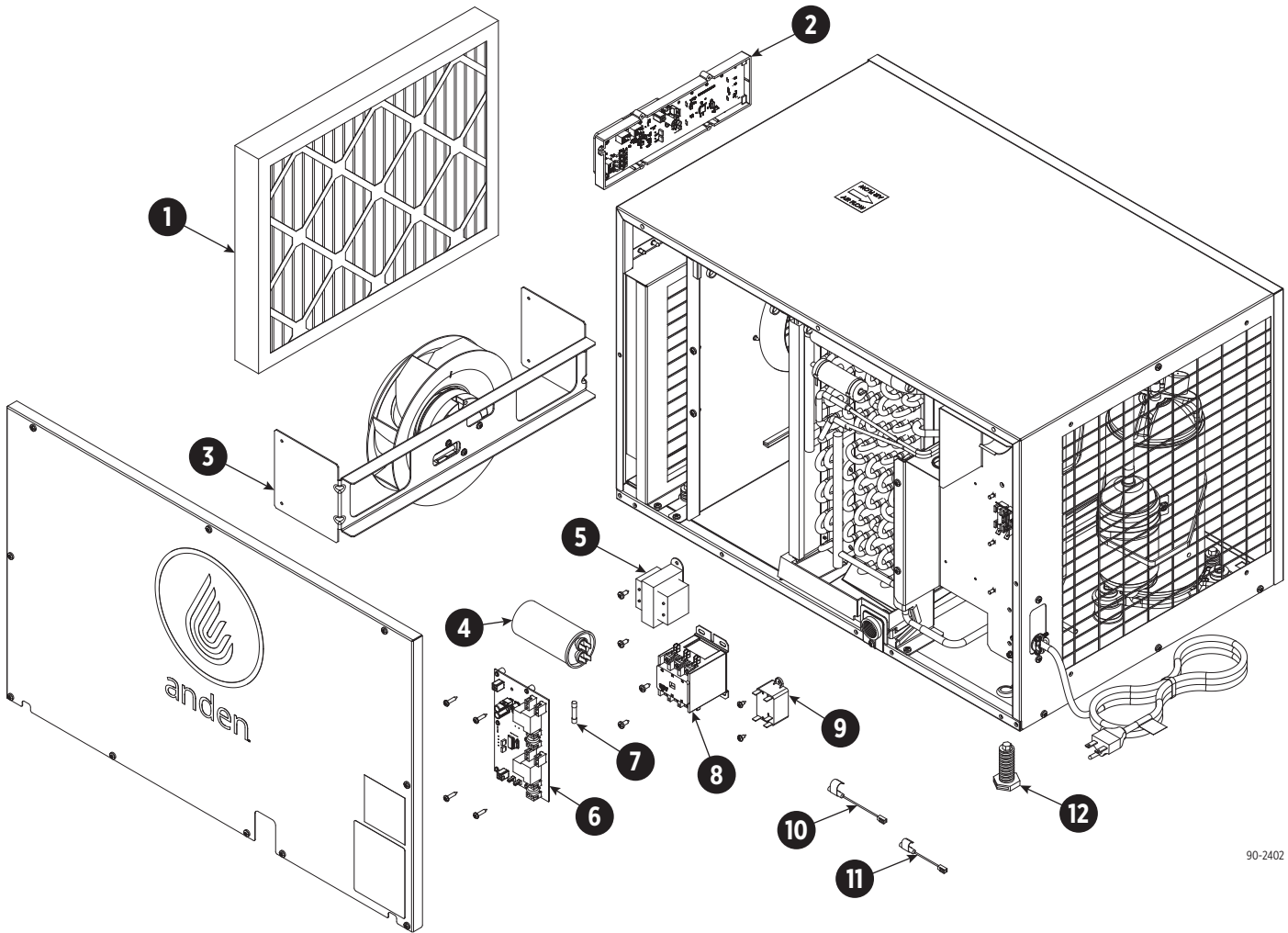

90-2402

No.	Part Description	Part No.
1	MERV 11 Replacement Filter	5781
2	User Interface	5738
3	Fan with Mounting Bracket	5782
4	Compressor Run Capacitor (40MFD, 370VAC)	5783
5	240:24 VAC Transformer, 40 VA	5784
6	Internal Power PCB	5444
7	Fuse, 1A Slow Blow	5785
8	Compressor Contactor	5714
9	Fan Relay	5787
10	Low Temperature Sensor	5455
11	High Temperature Sensor	5786

No.	Part Description	Part No.
12	Leveling Foot	5457
Not Shown		
	Digital Dehumidifier Control	A77
	Drain Tubing, 3/4" ID x 10' L	5740
	Duct Kit	5790
	Hanging Bracket Kit	5791
	Parts Bag • Screwdriver • T20 Drive Bit • 3/4 MNPT x 3/4 Hose Barb Drain Fitting • Model A77 Control • 30 ft. 20 AWG, 3-wire Thermostat Cable	5792
	Alert Light	5818

LIMITED WARRANTY

Your Research Products Corporation Anden™ Dehumidifier is expressly warranted for five (5) years from date of installation to be free from defects in materials or workmanship.

Research Products Corporation's exclusive obligation under this warranty shall be to supply, without charge, a replacement for any component which is found to be defective within such five (5) year period and which is returned not later than thirty (30) days after said five (5) year period by you to either your original supplier or to Research Products Corporation, Madison, Wisconsin 53701, together with the model number and installation date of the dehumidifier.

THIS WARRANTY SHALL NOT OBLIGATE RESEARCH PRODUCTS CORPORATION FOR ANY LABOR COSTS AND SHALL NOT APPLY TO DEFECTS IN WORKMANSHIP OR MATERIALS FURNISHED BY YOUR INSTALLER AS CONTRASTED TO DEFECTS IN THE DEHUMIDIFIER ITSELF.

IMPLIED WARRANTIES OF MERCHANTABILITY OR FITNESS FOR A PARTICULAR PURPOSE SHALL BE LIMITED IN DURATION TO THE AFORESAID FIVE YEAR PERIOD. RESEARCH PRODUCTS CORPORATION'S LIABILITY FOR INCIDENTAL OR CONSEQUENTIAL DAMAGES, OTHER THAN DAMAGES FOR PERSONAL INJURIES, RESULTING FROM ANY BREACH OF THE AFORESAID IMPLIED WARRANTIES OR THE ABOVE LIMITED WARRANTY IS EXPRESSLY EXCLUDED. THIS LIMITED WARRANTY IS VOID IF DEFECT(S) RESULT FROM FAILURE TO HAVE THIS UNIT INSTALLED BY A QUALIFIED HEATING AND AIR CONDITIONING CONTRACTOR. IF THE LIMITED WARRANTY IS VOID DUE TO FAILURE TO USE A QUALIFIED CONTRACTOR, ALL DISCLAIMERS OF IMPLIED WARRANTIES SHALL BE EFFECTIVE UPON INSTALLATION.

Some states do not allow limitations on how long an implied warranty lasts or the exclusion or limitation of incidental or consequential damages so the above exclusion or limitations may not apply to you.

This warranty gives you specific legal rights and you may also have other rights which vary from state to state.

WARRANTY REGISTRATION

Visit us online at anden.com to register your Anden product. If you do not have online access, please mail a postcard with your name, address, phone number, email address, product purchased, model number, date of purchase, and dealer name and address to: Research Products Corporation, P.O. Box 1467, Madison, WI 53701.

Your warranty registration information will not be sold or shared outside of this company.

anden.com
P.O. Box 1467
Madison, WI 53701-1467
800.972.3710 F: 608.257.4357
Printed in USA
©2019 Anden – A Quality brand from Research Products Corporation

