

USER MANUAL

ACTIVE AIR®

DEHUMIDIFIER (80 AND 110 PINT)



AADHC602P and AADHC1002P



Hydrofarm.com

TABLE OF CONTENTS

OVERVIEW	4
FEATURES	4
WARNINGS	4
SPECIFICATIONS	4
PRODUCT DRAWINGS	5
DRAINAGE INSTALLATION	6
DRAINAGE WITH THE BUILT-IN WATER TANK	6
CONTINUOUS DRAINAGE WITH THE DRAINAGE PIPE	6
MACHINE SETUP AND OPERATION	7
KEY FUNCTIONS	7
HUMIDITY AND TIMER SETUP	7
OPERATIONS	8
MAINTENANCE	10
MACHINE STORAGE	11
TROUBLE SHOOTING	11

OVERVIEW

Thank you for selecting the Active Air AADHC602P or AADHC1002P dehumidifier. This manual details the proper use and maintenance of your dehumidifier. Please take a few minutes to read this manual, and please keep it for further reference.

Active Air industrial-grade dehumidifiers provide powerful and reliable dehumidification solutions for grow room environmental control. These units have been designed for improved efficiency, performance and increased water removal capabilities. The digital humidistat is programmable for precise and automatic control of indoor humidity levels. The units can be operated 24/7 for continuous use or programmed for timed operation.

These updated dehumidifiers are equipped with automatic restart, allowing them to be used with external humidity controllers. The digital humidistat display has a lithium ion battery backup that maintains programmed settings during unexpected power outages or after daily on/off cycles. The internal air filter collects airborne particles helping keep your indoor environment and plants as healthy as possible. The filter is washable for repeated use. All three models are ETL-listed. They have a one-year warranty and are equipped with caster wheels for easy and secure placement.

For information on additional Active Air products please visit Hydrofarm.com.

FEATURES

- Removes up to 80 pints per day (AADHC602P)/110 pints per day (AADHC1002P)
- Automatic Restart (humidity controller compatible)
- Programmable humidity setting
- Timed operation
- Continuous draining option
- Low decibel output
- Digital humidistat control
- Caster wheels for easy mobility and storage

WARNINGS

- Please follow the below safety guidelines when using the dehumidifier:
- Unplug the power supply when cleaning or storing the unit.
- Do not put into water or operate near a water source.
- Do not place the unit near the heating equipment or flammable substances .
- Keep fingers and other objects away from air inlets and outlets.
- Do not stand on the unit.
- Do not cover the louvered panels on the machine or it will overheat.
- Install the drainpipe facing downward so condensation will flow out of the pipe.
- If the power cable is damaged, please contact a licensed electrician for replacement or repair.

SPECIFICATIONS		
MODEL#	AADHC602P	AADHC1002P
Rated capacity	Up to 40 Pints/Day @ 80°F, 60% RH Up to 80 Pints/Day @ 86°F, 80% RH	Up to 70 Pints/Day @ 80°F, 60% RH Up to 1100 Pints/Day @ 86°F, 80% RH
Power supply	115VAC/60Hz	115VAC/60Hz
Power consumption and current	550W/4.05A @ 80°F, 60% RH 520W/4.65A @ 86°F, 80% RH	635W/6.0A @ 80°F, 60% RH 728W/6.75A @ 86°F, 80% RH
Refrigerant type & capacity	R410A/11.3 oz (320 g)	R410A/11.6 oz (330 g)
Maximum design pressure	High Side: 522 psig (3.6MPa) Low Side: 240 psig (1.65MPa)	High Side: 522 psig (3.6MPa) Low Side: 240 psig (1.65MPa)

FRONT

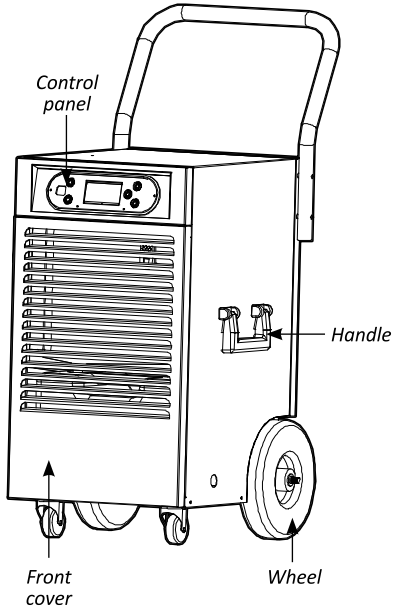

BACK

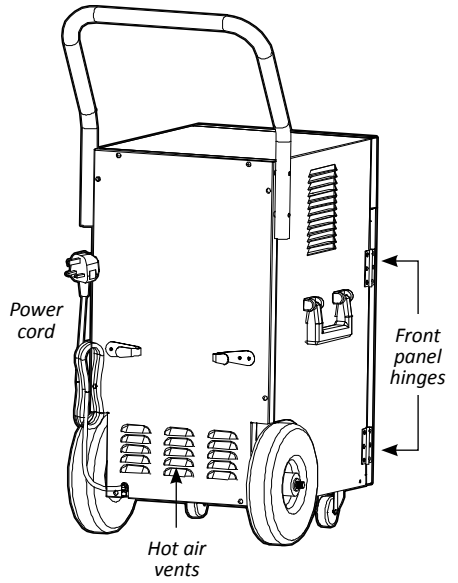

FRONT, OPEN

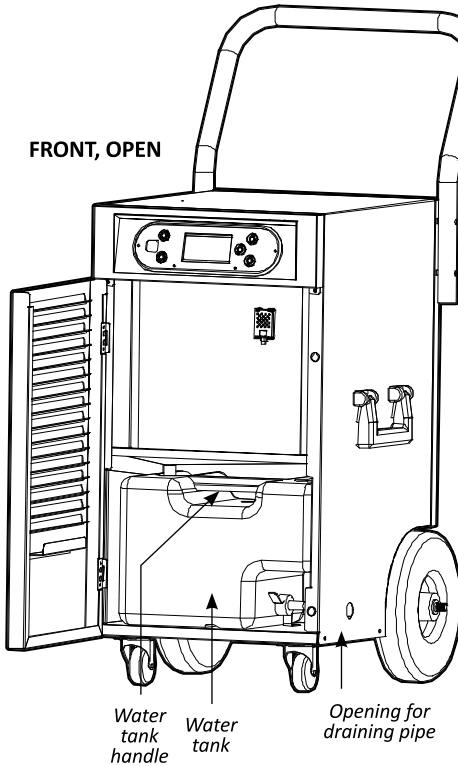

DRAINAGE INSTALLATION

DRAINAGE WITH THE BUILT-IN WATER TANK

The unit is designed to use the built-in water tank for drainage by default. When the tank is full, the screen will display "FULL" and also make a buzzing sound.

1. Press the **POWER** button to turn off the machine.
2. To empty the water tank, open the front panel to access the water tank.
3. Grab the handle of the water tank and pull it out horizontally.
4. After disposing of the water, insert the tank back into place until you feel the internal clamp fully clamp onto the nozzle of the tank. Close the front panel.
5. Press the **POWER** button to resume operation.

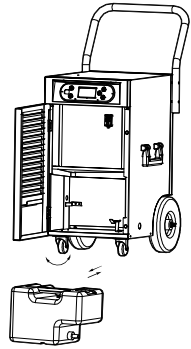

CONTINUOUS DRAINAGE WITH THE DRAINAGE PIPE

In extremely wet conditions, the water tank may be filled up frequently. You may consider setting up continuous drainage by using the drainage pipe for convenience.

1. Open the front cover of the machine, remove the tank, and empty the water from the tank.
2. Screw the water pipe connector off the water tank outlet. Set the connector aside.
3. The outlet at the side of the water tank is sealed by default for drainage. If you decide to install a pipe for continuous drainage, use a power tool to drill the side outlet so you to have an opening of sufficient size to allow water to drain through smoothly.
4. Screw the connector back to the outlet tightly. A washer is pre-installed into the connector to prevent leakage.

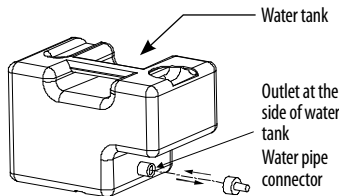

5. Install the included drain pipe to the water pipe connector on the tank, through the opening on the machine housing. Direct the pipe to the desired area before operating the machine.
6. If needed to replace or extend the drainage pipe, use 7/16" (ID Φ 11 mm) piping.
7. Shut the front panel.

WARNING: Do not block the drainage pipe. The end of the drainage pipe should not be higher than the water tank outlet. If the drainage pipe end is higher than the outlet, water will not drain properly and could damage components of the unit.

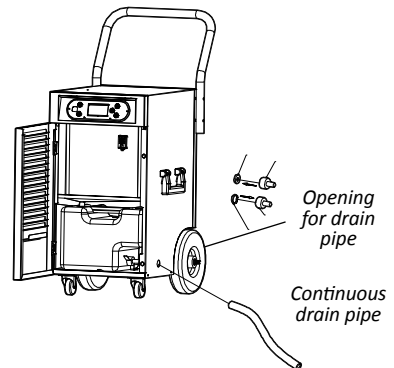

KEY FUNCTIONS

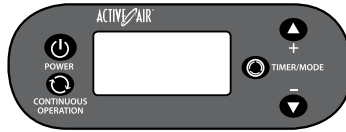

POWER – Turns the unit on and off.

CONTINUOUS OPERATION – When pressed, the unit will operate continuously.

TIMER/MODE – The unit has 5 modes: Humidity, Current Time, Timed Operation On, Timed Operation Off, and Exit. Every time you press the Timer/Mode button it cycles to the next mode.

“+” BUTTON – When in the **“SET”** mode, every time you press the **“+”** button, it will raise the humidity by 1%. If you hold the button down, it will add humidity more quickly. When in any of the time modes, the **“+”** button adds hours. These buttons are used to set **“CURRENT”** time, **“TIMING ON”**, and **“TIMING OFF”**.

“-” BUTTON – When in the **“SET”** mode, every time you press the **“-”** button, it will lower the humidity by 1%. If you hold the button down, it will lower humidity more quickly. When in any of the time modes, the **“-”** button adds minutes. These buttons are used to set **“CURRENT”** time, **“TIMING ON”**, and **“TIMING OFF”**.

HUMIDITY AND TIMER SETUP

When the machine is powered on for the first time, there will be an audible buzz sound. Press the **POWER** button to start the machine. The screen will display **“Run”** and **“Current”**, the present

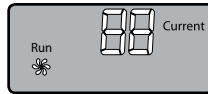

humidity.

- To set the desired humidity, press the **TIMER/MODE** button. The screen shows **“Set”** and the

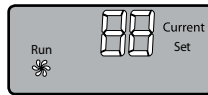

machine enters into the set mode. When in the set mode, you can increase or decrease the humidity from the default setting to your desired level by using the **“+”** or **“-”** buttons.

ATTENTION: *The machine’s default humidity setting may be lower or higher than the current ambient humidity when the machine is powered on for the first time. If the default humidity is higher than the current humidity, after the machine is powered on, although the fan will operate, the dehumidify function will not operate. You are required to reset the humidity to your desired level in order to ensure the machine will operate properly.*

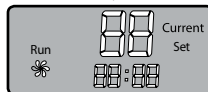

- To set the current time, press **TIMER/MODE** again to see the present time. You can change the time by using the **“+”** button to change hours and **“-”** button to change minutes.

ATTENTION: *The time format is in 24 hours and the default time is set at 12:00. You can choose to skip the current time setting by pressing the **TIMER/MODE** button to cycle to exit. However, if the*

machine operates by the default current time, the **Timing On** and **Timing Off** function, if set, will operate according to the default current time, but not the real current time. We strongly recommend that you set the current time.

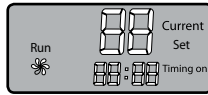

- To set for timed operation, press **TIMER/MODE** a third time and "Timing on" will display. Use the

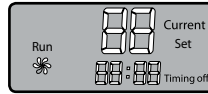

"+" button to change hour and the "-" button to change minutes. The timer is in 24-hour format.

- After you press **TIMER/MODE** a fourth time, "**Timing off**" will display. Use the "+" button to change hour and the "-" button to change minutes.

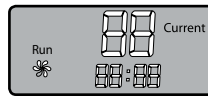

TIP: You can choose to skip the **Timing on** and **Timing off** setting by pressing the **TIMER/MODE** button to exit. If so, you must manually power the machine on or off each time by pressing the **POWER** button.

- Press **TIMER/MODE** a fifth time to exit the setting mode.

OPERATIONS

Non-timed dehumidifying operation to the desired humidity level

When the timer is not set, the unit dehumidifies up to the humidity set point and automatically goes to the standby mode when the set point is achieved. After the ambient humidity increases more than 3%, the dehumidifying function operates again. The machine will continue working in this pattern until it is manually powered off.

Due to the 3-minute on/off delay design to protect the working components (see *On/Off Delay*, page 9), the humidity reading may go up more than 3% while the machine remains in the standby mode since it is within the 3-minute delay protection period. This usually happens under conditions where the ambient humidity is high. It is not a machine malfunction.

Timed dehumidifying operation to the desired humidity level

When the timer is set, the machine will operate according to the humidity set point (see page 7, step 2), only after the **Timing On** time and before the **Timing Off** time. Before the **Timing On** time and after the **Timing Off** time, the machine is in standby mode. Unless the power supply cord is unplugged, the machine remembers all set points in the standby mode and will automatically operate according to the timer setup every day.

You can manually override the timer function to start or stop the dehumidifying function by pressing the **POWER** button. The machine resumes to the timer mode in the next 24-hour cycle.

Automatic Defrost

The unit will automatically go into defrost mode when frost forms on the evaporator coil. The screen shows "**Defrost.**" After 15 minutes of defrost time the unit will resume operation. When in the defrost mode, the unit does not dehumidify.

Continuous dehumidifying operation

NOTE: Use this setting when operating this dehumidifier with a timed humidity controller.

When the machine is in continuous operation, the desired humidity set point is still remembered but is deactivated. The machine will continuously dehumidify, no matter what the humidity set point is, until it is manually powered off or timed off.

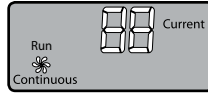

1. Press the **CONTINUOUS OPERATION** button to enter the continuous operation mode. The screen will show "**Continuous.**"
2. Press the **CONTINUOUS OPERATION** button again to deactivate continuous operation. The machine goes back to the mode of operating according to the humidity set point.

When there is a frost buildup, the machine will be forced to stop dehumidifying and start defrosting automatically. The screen shows the machine in "**Defrost**" process under "**Continuous**" mode. After the defrost function ends, "**Defrost**" disappears from the screen while "**Continuous**" still shows.

Automatic Restart

In the event of a power failure, the machine will remember what the humidity set point was and whether the unit was in operating mode before the power failure.

When power is restored, if the unit was operating before the power failure, it automatically restarts to operate according to the humidity set point in the non-timed mode.

Note that the unit was powered off when a power failure occurs, the unit will remain powered off until it is turned back on.

The Automatic Restart feature allows the unit to be used with controllers and timers.

On/Off Delay

If the system is turned off after running and you wish to turn it on again, there is a 3-minute delay before restart as protection to the working components of the unit.

MAINTENANCE

1. Clean the machine with a soft wet cloth.
2. Pull out the louver on the front panel to gain access to the filter.

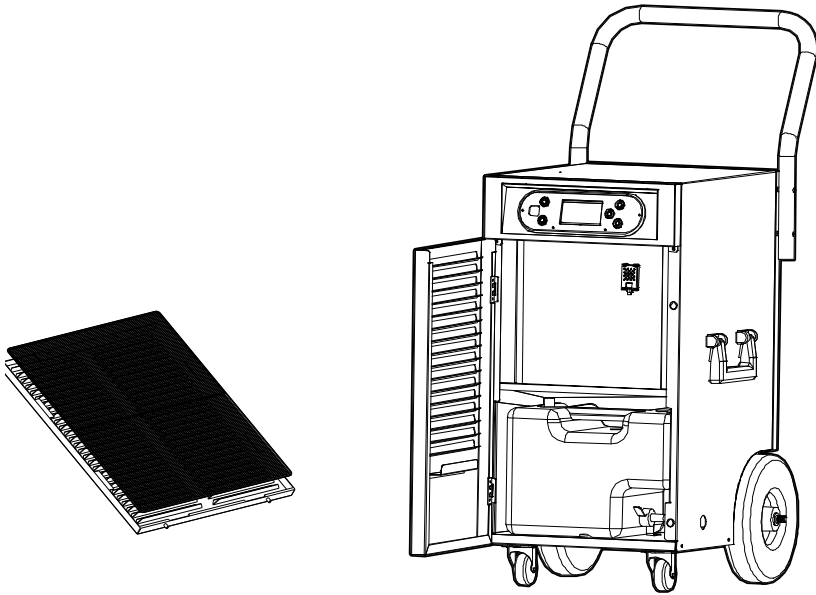

3. Remove the filter mesh from the unit.
4. Use a clean rag to absorb the surface dust on the filter mesh. If the filter is extremely dirty, use tap water to flush the filter. Fully dry the filter before putting it back into the air inlet fence. A clean filter will increase the machine's capacity.

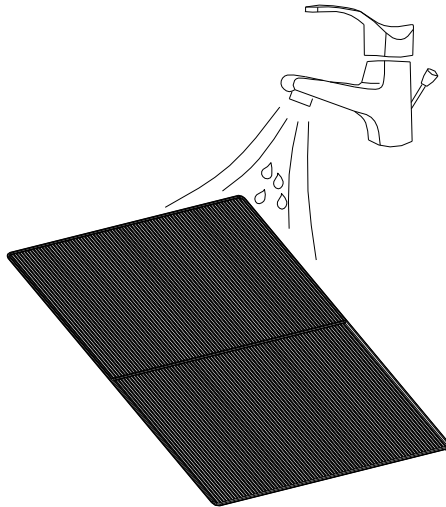

MACHINE STORAGE

If you will not be using the unit for an extended period of time, please store it per the following steps.

- Clean the filter mesh.

ATTENTION: The evaporator inside the machine has to be dried out before the unit is packed to avoid component damage and molds. Unplug the unit and place it in a dry open area for a few days to dry it out.

TIP: Another way to dry the unit is to set the humidity point higher than the ambient humidity to force the fan to dry the evaporator for 30 minutes. The dehumidifying function will not work and the fan can accelerate the drying process.

- Collect the power cord, bunch it, and hang it in the power cord pocket at the back of unit.
- Store the unit in a clean, dry environment.

TROUBLESHOOTING

TROUBLE	CAUSE	SOLUTION
Machine does not run	Unit is not plugged in.	Plug in the unit.
	Ambient temperature is under 5 degrees or above 35 degrees.	To protect the machine, use it only when ambient temperature is between 5 and 35 degrees.
	The humidity sensor is loose, wet or defective; the screen will show "E5".	Check the sensor connection. Use a blower to dry the humidity sensor behind the front cover. If the machine still does not run, contact your retailer to replace the sensor.
	The temperature sensor is loose or defective; the screen will show "E6".	Check the sensor connection. Contact your retailer to replace the sensor.
Machine runs but does not dehumidify	The humidity set point is higher than the ambient humidity.	Reset the humidity to a lower set point, or power off the machine if the desired humidity level has been reached.
Reduced dehumidifier capacity	Filter mesh is jammed.	Clean the filter mesh according to manual.
	Air-in and/or Air-out louvers are jammed.	Clear the blockage from Air-in and/or Air-out louvers.
No air inlet	Filter mesh or Air-in louver is jammed.	Clean filter according to instructions or clean the louver blockage.
Loud Operation	Machine is situated on an incline or decline slope.	Move to a level location.
	Filter mesh is jammed.	Clean filter mesh according to instructions.

WARRANTY



LIMITED WARRANTY

Hydrofarm warrants the **AADHC602P** or **AADHC1002P** to be free from defects in materials and workmanship. The warranty term is for 1 year beginning on the date of purchase. Misuse, abuse, or failure to follow instructions is not covered under this warranty. Hydrofarm's warranty liability extends only to the replacement cost of the product. Hydrofarm will not be liable for any consequential, indirect, or incidental damages of any kind, including lost revenues, lost profits, or other losses in connection with the product. Some states do not allow limitation on how long an implied warranty lasts or the exclusion of incidental or consequential damages, so the above limitations or exclusions may not apply to you. Hydrofarm will, at our discretion, repair or replace the **AADHC602P/AADHC1002P** covered under this warranty if it is returned to the original place of purchase. To request warranty service, please return the **AADHC602P/AADHC1002P**, with original sales receipt and original packaging, to your place of purchase. The purchase date is based on your original sales receipt.



Thank you for choosing Active Air by Hydrofarm. For further information about Active Air products, videos, and technical information, please visit Hydrofarm.com

ADDITIONAL LANGUAGES OF THESE INSTRUCTIONS CAN BE FOUND AT Hydrofarm.com



Get Connected with the Hydrofarm Community:



Like us on Facebook, follow us on Twitter, and check out **Hydrofarmtv** on YouTube and Instagram!

AADHC602P_AADHC1002P_Instructions revised - January 8, 2018 10:10 AM



Hydrofarm.com